

NOFERR[®]

H₂O

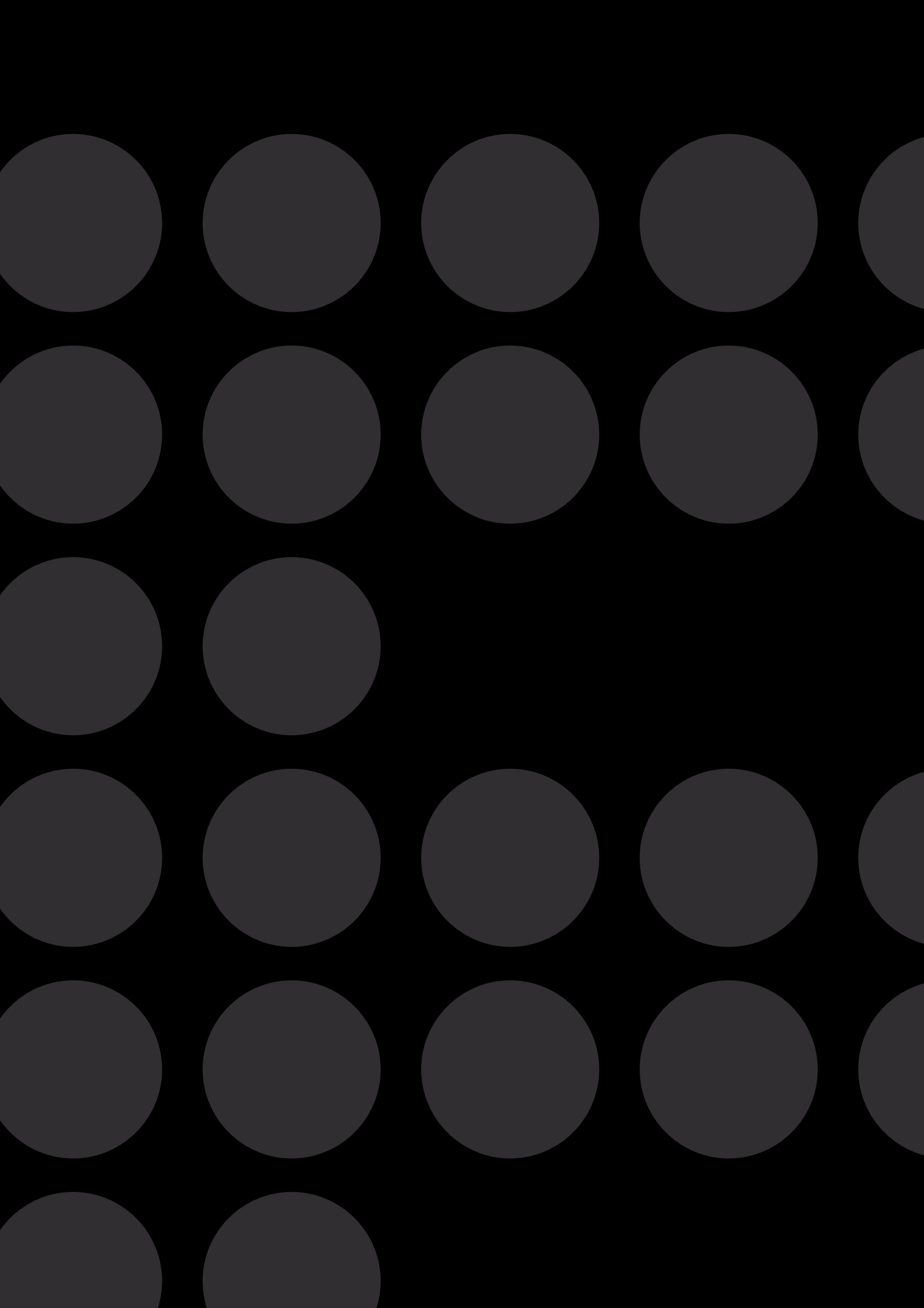

2024



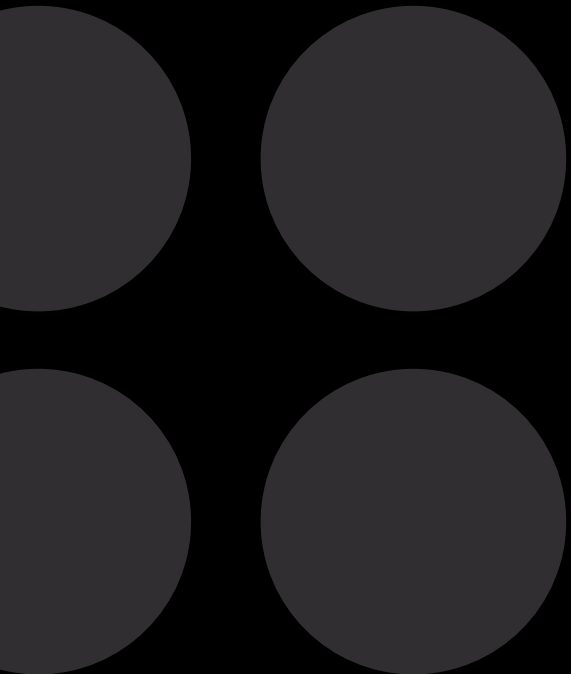

NOIFER®

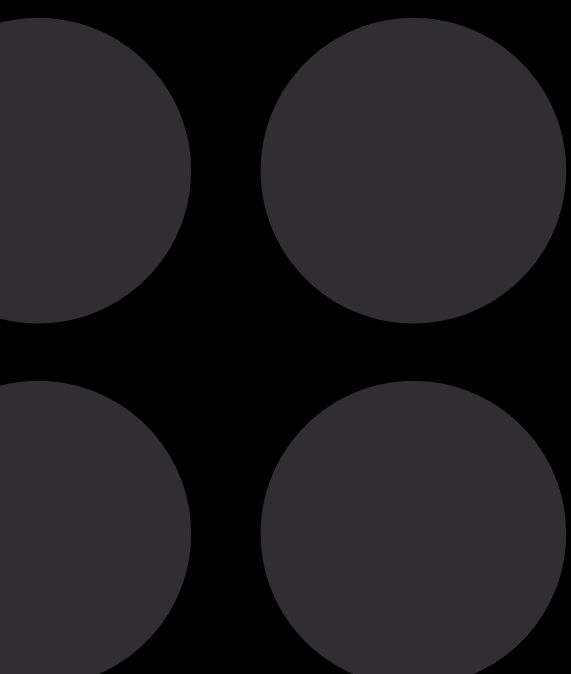



ÍNDICE



ÍNDICE



INDICE



INDEX

6

- Concept³
- Concept³
- Concept³
- ⊙ Concept³

18

- MUMO
- MUMO
- MUMO
- ⊙ MUMO

50

- Grifería electrónica
- Torneira eletrônica
- Rubinetteria elettronica
- ⊙ Robinet électronique

84

- Grifería temporizada
- Torneiras temporizadas
- Rubinetteria temporizzata
- ⊙ Robinets temporisés

136

- Grifería de pedal
- Torneiras a pedal
- Rubinetteria a pedale
- ⊙ Robinet à pedale

142

- Grifería gerontológica
- Torneiras gerontológicas
- Rubinetteria per anziani e disabili
- ⊙ Robinet hospitalier

148

- Grifería industrial
- Torneira industrial
- Rubinetteria industriale
- ⊙ Robinets industriels

154

- Soluciones antivandálicas
- Soluções anti-vandalismo
- Soluzioni anti-vandalo
- ⊙ Solutions anti-vandalisme

180

- Repuestos
- Peças de reposição
- Pezzi di ricambio
- ⊙ Pièces de rechange

CONCEPT³









CONCEPT³ Revolucionario
conjunto de grifería con secamanos,
dosificador de jabón y agua en una
sola pieza



CONCEPT³ conjunto de torneira
com secador de mãos, dispensador
de água e sabonete em uma só
peça



CONCEPT³ rivoluzionario prodotto
3 in 1 con asciugamani , dosatore di
sapone ed acqua



CONCEPT³ ensemble de robinet
révolutionnaire avec sèche-mains,
distributeur de savon et eau en un
seul produit

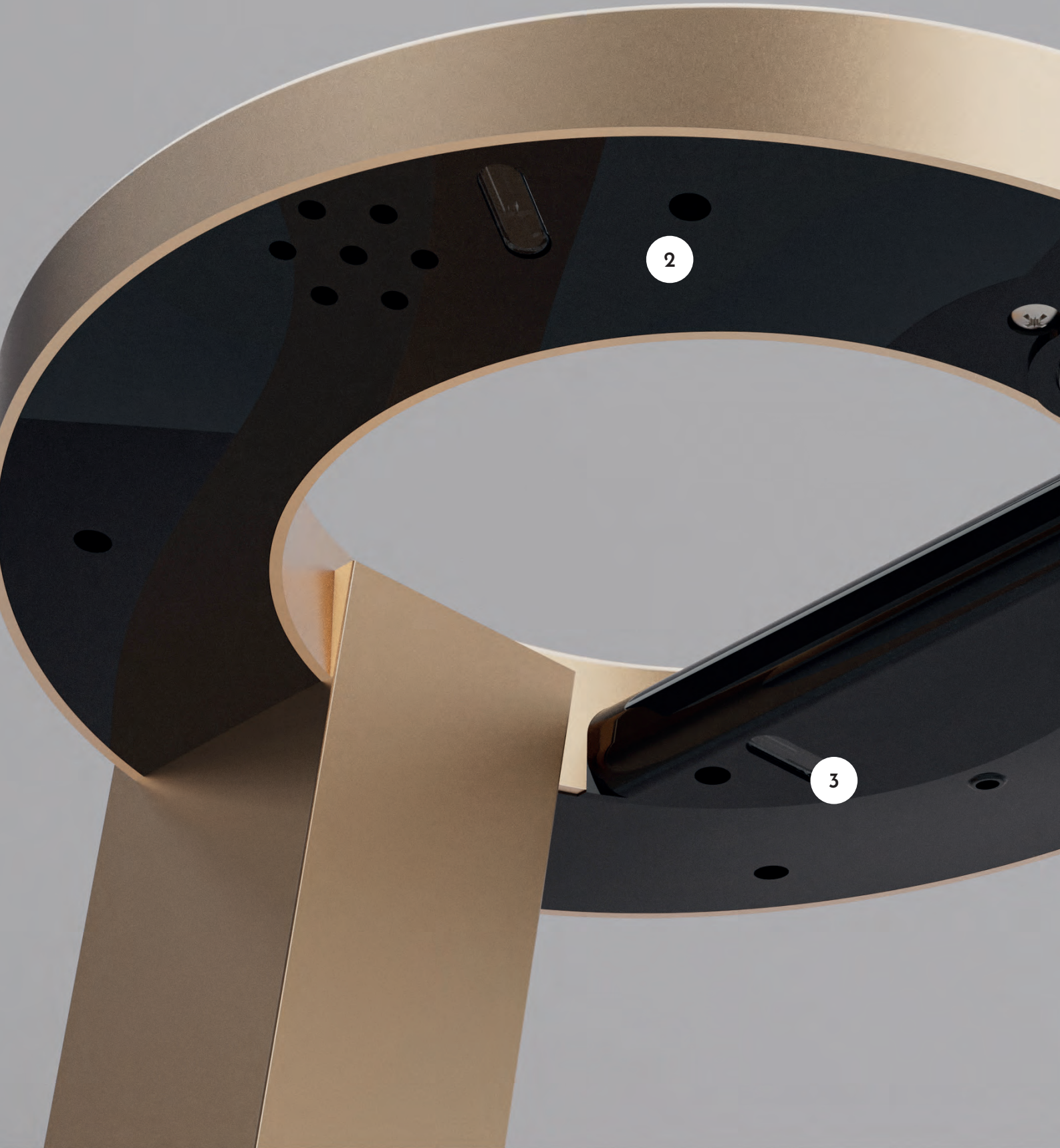

2

3

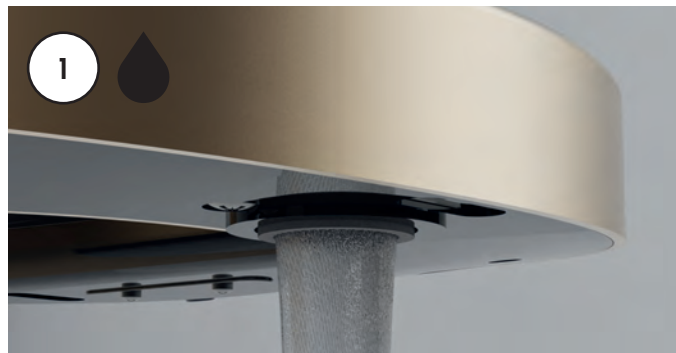

- Aireador Slim 5 l/min. - 1,3 GPM. Incluido aireador Spray 1,89 l/min - 0,5GPM
- Arejador Slim 5 l/min. - 1,3 GPM. Incluido arejador Spray 1,89 l/min - 0,5 GPM
- Aeratore Slim incluso 5 l/min. - 1,3 GPM. Aeratore Spray incluso 1,89 l/min - 0,5 GPM
- Aérateur Slim 5 l/min. - 1,3 GPM. Aérateur Spray 1,89 l/min - 0,5 GPM inclus



- Bajo impacto sonoro, solo 70 dB
- Baixo impacto de som, so 70 dB
- Basso impatto sonoro solo 70 dB
- Faible impact sonore, uniquement 70 dB



- Dosificador de jabón auto-limpieza.
Descarga automática para higienización
- Doseador de sabão autolimpante.
Descarga automática para higienização
- Dosatore di sapone auto pulente.
Scarico automatico per igienizzazione
- Distributeur de savon autonettoyant.
Déclenchement automatique pour la désinfection

TECNICS

○ ACABADOS ● ACABADO ● FINITURE ◎ FINITION

○ Nuestra selección de 4 colores atemporales que combinan con el diseño innovador Concept³

Oro, brillo, negro, plata.
Atemporalidad, versatilidad, elegancia

● Nossa seleção de 4 cores atemporais que combinam com o design inovador do Concept³

Ouro, brilho, preto, prata. Atemporalidade, versatilidade, elegância

● Nostra selezione di 4 colori sempre attuali che si associano al design innovativo del Concept³

Oro, lucido, nero, argento, Modernità, versatilià, eleganza

◎ Notre sélection de 4 couleurs intemporels qui combinent au design innovant du Concept³

Or, brillant, noir, argent.
Intemporalité, polyvalence, élégance



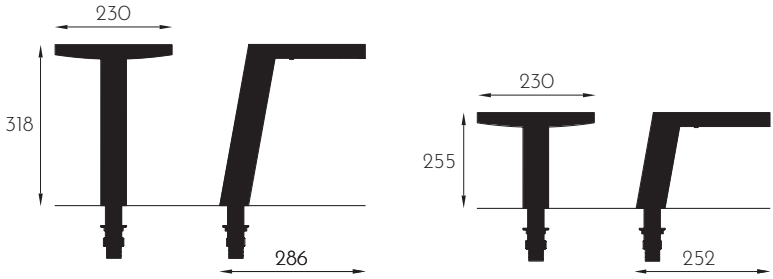

- negro ● preto
- nero ⊙ noir



- plata ● prata
- argento ⊙ argent





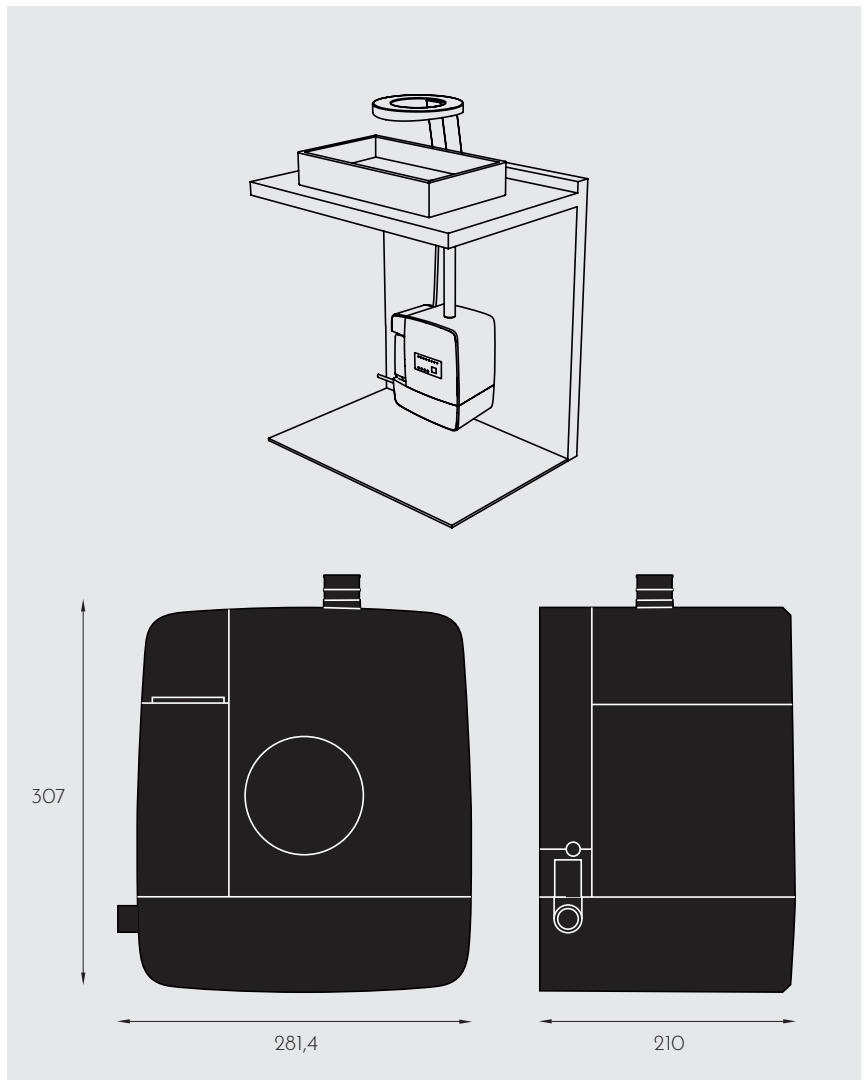

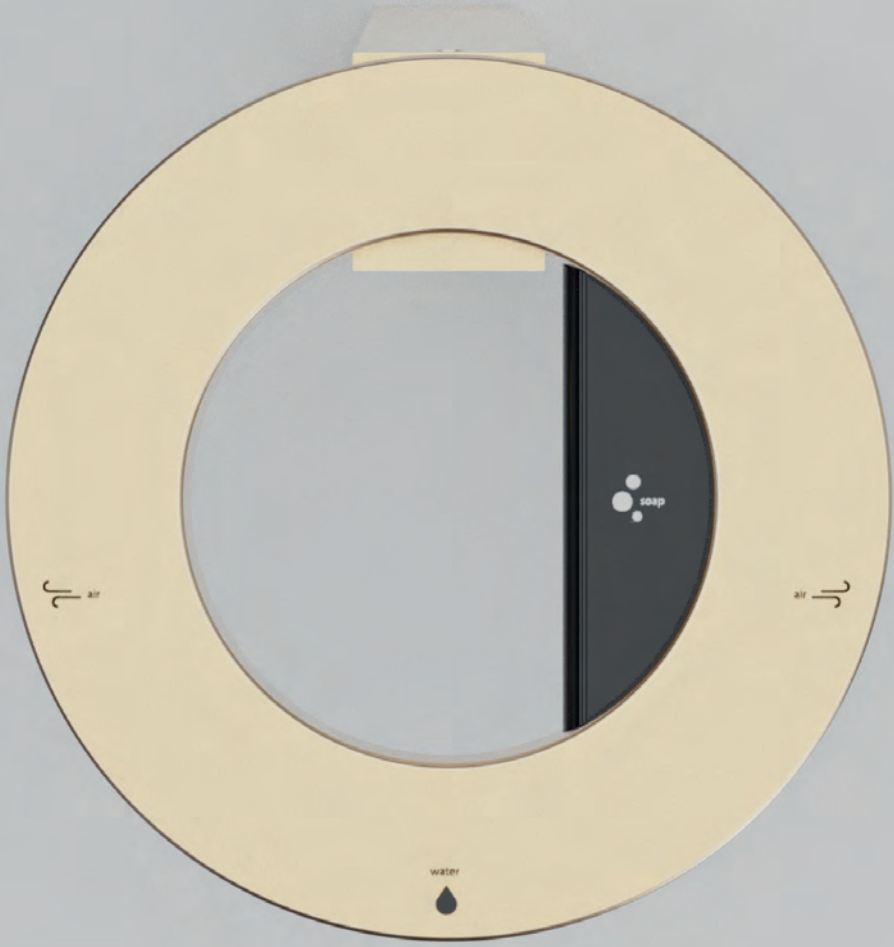

○ ESPECIFICACIONES TÉCNICAS

DISPENSADOR / GRIFO

Peso modelo alto: 2 Kg
Peso modelo bajo: 1,8 Kg
Activación: sensor láser
Sensibilidad regulable
Columna de Aluminio extrusionado 6063 T5
01901.B y 01902.B: cromado de acuerdo con la norma EN248
01901.S y 01902.S: arenado. Anodizado de acuerdo con las normas ISO 15184/ISO 9227 / ISO 1134
01901.N y 01902.N: arenado. Anodizado de acuerdo con las normas ISO 15184/ISO 9227 / ISO 1134
01901.GD y 01902.GD: arenado. Anodizado de acuerdo con las normas ISO 15184/ISO 9227 / ISO 1134

DOSIFICADOR DE JABÓN
Sistema de dosificación: bomba peristáltica
Capacidad depósito: 1,2 l

MÓDULO DE CONTROL

Peso: 3,8 Kg
Instalación: mural o apoyo a suelo con 'silentblocks'
Parámetros regulables: sensor test, purgado circuito de jabón, selector dosificación de jabón, tiempo de operación, regulación temperatura del agua

SECAMANOS

Potencia: 1200 W
Velocidad del motor: 32000 rpm
Temperatura del aire: 40°C a 10 cm

VÁLVULA SOLENOIDE

Presión de trabajo: máx. 8 - mín. 0,5 bar
Presión recomendada: 3 bar

● ESPECIFICAÇÕES TÉCNICAS

DOSEADOR / TORNEIRA

Peso do modelo alto: 2 Kg
Peso do modelo baixo: 1,8 kg
Ativação: sensor laser
Sensibilidade ajustável
6063 Coluna de Alumínio Extrudado T5
01901.B e 01902.B: cromado de acordo com a norma EN248
01901.S e 01902.S: Arenado. Anodizado de acordo com os standards ISO 15184 / ISO 9227 / ISO 1134
01901.N e 01902.N: Arenado. Anodizado de acordo com os standards ISO 15184 / ISO 9227 / ISO 1134
01901.GD e 01902.GD: Arenado. Anodizado de acordo com os standards ISO 15184 / ISO 9227 / ISO 1134

SABONETEIRA
Sistema de dosagem: bomba peristáltica
Capacidade do tanque: 1,2 l

MÓDULO DE CONTROLE

Peso: 3,8 Kg
Instalação: suporte de parede ou piso com 'silentblocks'
Parâmetros ajustáveis: sensor de teste, purga do circuito de sabão, seletor de dosagem de sabão, tempo de operação, regulação da temperatura da água

SECADORES DE MÃO

Potência: 1200 W
Velocidade do motor: 32000 rpm
Temperatura do ar: 40 ° C a 10 cm

VÁLVULA DE SOLENÓIDE DE ÁGUA

Pressão de trabalho: máx. 8 - mín. 0,5 bar
Pressão recomendada: 3 bar

● SPECIFICHE TECNICHE

DISTRIBUTORE / RUBINETTO

Peso del modello alto: 2 Kg
Peso del modello basso: 1,8 Kg
Attivazione: sensore laser
Sensibilità regolabile
Colonna in alluminio estruso 6063 T5
01901.B e 01902.B: cromato secondo norma EN248
01901.S e 01902.S: sabbiato. Anodizzato secondo gli standard ISO 15184 / ISO 9227 / ISO 1134
01901.N e 01902.N: sabbiato. Anodizzato secondo gli standard ISO 15184 / ISO 9227 / ISO 1134
01901.GD e 01902.GD: sabbiato. Anodizzato secondo gli standard ISO 15184 / ISO 9227 / ISO 1134

EROGATORE DI SAPONE
Sistema di dosaggio: pompa peristaltica
Capacità del serbatoio: 1,2 l

MODULO DI CONTROLLO

Peso: 3,8 Kg
Installazione: supporto a parete o a pavimento con 'silentblock'
Parametri regolabili: sensore di prova, spurgo del circuito del sapone, selettore del dosaggio del sapone, tempo di funzionamento, regolazione della temperatura dell'acqua

ASCIUGAMANI

Potenza: 1200 W
Regime motore: 32000 giri/min
Temperatura dell'aria: 40 ° C a 10 cm

ELETTROVALVOLA ACQUA

Pressione di lavoro: max. 8 - min. 0,5 bar
Pressione consigliata: 3 Bar

◎ SPÉCIFICATIONS TECHNIQUES

DISTRIBUTEUR / ROBINET

Poids du modèle haut : 2 Kg
Poids du modèle bas : 1,8 Kg
Déclenchement: capteur laser
Sensibilité réglable
Colonne en aluminium extrudé 6063 T5
01901.B et 01902.B : chromés selon la norme EN248
01901.S et 01902.S : sablé. Anodisé selon les normes ISO 15184 / ISO 9227 / ISO 1134
01901.N et 01902.N : sablé. Anodisé selon les normes ISO 15184 / ISO 9227 / ISO 1134
01901.GD et 01902.GD : sablé. Anodisé selon les normes ISO 15184 / ISO 9227 / ISO 1134

DISTRIBUTEUR DE SAVON

Système de dosage: pompe péristaltique
Capacité du réservoir : 1,2 l

MODULE DE COMMANDE

Poids: 3,8 Kg
Installation: murale ou support au sol avec 'silentblocks'
Paramètres réglables: capteur de test, purge du circuit de savon, sélecteur du dosage de savon, durée de fonctionnement, réglage de la température de l'eau

SÈCHE-MAINS

Puissance: 1200W
Vitesse du moteur: 32000 rpm
Température de l'air: 40°C à 10 cm

ELECTROVANNE D'EAU

Pression de fonctionnement: 8 - min. 0,5 bar
Pression recommandée: 3 bar



M U M O

MULTI MODULAR BY NOFER







Sistema modular integrado tras espejo expertamente diseñado para el ahorro de agua, energía, espacio, tiempo y recursos



Sistema modular integrado atrás do espelho projetado habilmente para economizar água, energia, espaço, tempo e recursos



Sistema modulare integrato tra specchio disegnato competentemente per il risparmio di acqua, energia, spazio, tempo e risorse



Système modulaire intégré derrière le miroir conçu pour économiser eau, énergie, espace, temps et ressources

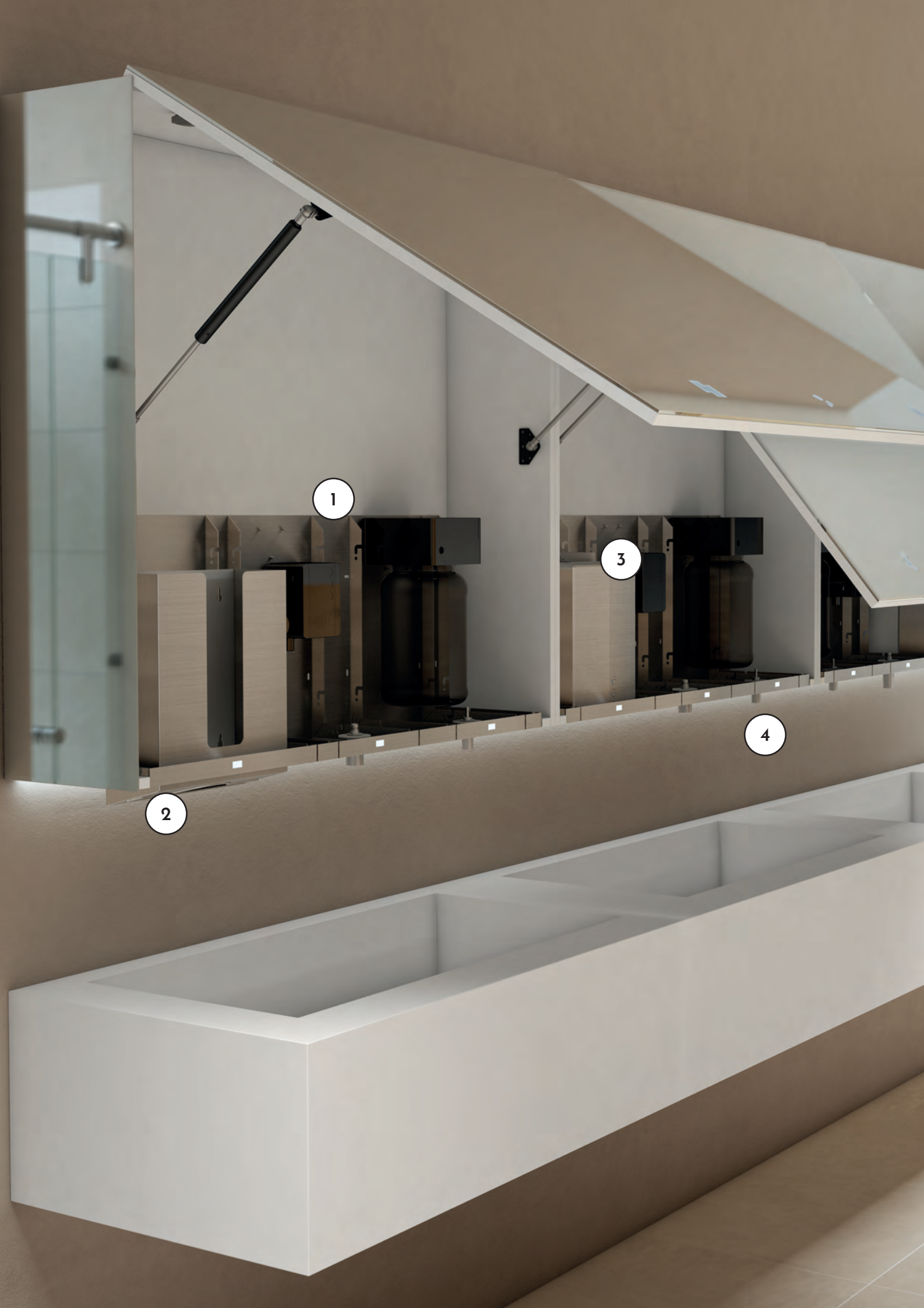

1

3

4

2



- Grifo con sensor laser regulable
- Torneira com sensor láser regulável
- Rubinetto con sensore laser
- Robinet avec capteur laser réglable

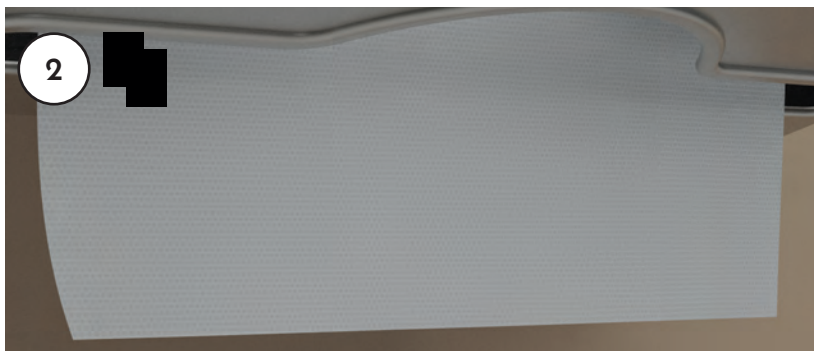

- Dispensador de papel contactless manual o automático
- Dispensador de papel contactless manual ou automático
- Dispenser di carta contactless manuale o automatico
- Distributeur de papier contactless manuel ou automatique



- Bajo impacto sonoro, entre 60 y 70 dB
- Baixo impacto de som, entre 60 e 70 dB
- Basso impatto sonoro tra i 60 e 70 dB
- Faible impact sonore, entre 60 y 70 dB



- Dosificador de jabón auto-limpieza. Descarga automática para higienización
- Doseador de sabão autolimpante. Descarga automática para higienização
- Dosatore di sapone auto-pulente. Scarico automatico per igienizzazione
- Distributeur de savon. Autonettoyant. déclenchement automatique pour la désinfection



Laser faucet



12053.M

370 x 200 x 223 mm

- Sensor láser
- Distancia de activación y tiempo de funcionamiento regulable con mando
- 220 AC 50/60 Hz
- Alternativa batería recargable
- 3 / 1,89 l/min

- Sensor laser
- Activação a distancia e tempo de funcionamento regulable com control
- 220 AC 50/60 Hz
- Bateria recarregável alternativa
- 3 / 1,89 l/min

- Sensore laser
- Distanza di attivazione e tempo di funzionamento regolabile con telecomando
- 220 AC 50/60 Hz
- Alternativa con batteria ricaricabile
- 3 / 1,89 l/min

- Capteur laser
- Distance d'activation et temps de fonctionnement réglable avec commande
- 220 AC 50/60 Hz
- Batterie alternative rechargeable
- 3 / 1,89 l/min



Laser soap

12053.S1

440 x 200 x 223 mm



Automatic soap

12053.S2

370 x 150 x 223 mm

- • Sensor láser
- Distancia de activación y tiempo de funcionamiento regulable con mando
- 220 AC 50/60 Hz
- Alternativa batería recargable
- Capacidad 3 litros

- • Sensor laser
- Activação a distancia e tempo de funcionamento regulable com control
- 220 AC 50/60 Hz
- Bateria recarregável alternativa
- Capacidade 3 litros

- • Sensore laser
- Distanza di attivazione e tempo di funzionamento regolabile con telecomando
- 220 AC 50/60 Hz
- Alternativa con batteria ricaricabile
- Capacità 3 litri

- ○ • Capteur laser
- Distance d'activation et durée de fonctionnement réglable avec commande
- 220 AC 50/60 Hz
- Alternative batterie rechargeable
- Capacité 3 litres

- • Sensor infrarrojos
- Funciona con baterías AA (4 unidades)
- Alternativa 230V AC con transformador
- Posibilidad válvula de jabón líquido, espuma o spray
- Capacidad 1 litro

- • Sensor infravermelho
- Operado por baterías AA (4 unidades)
- Alternativa 230 V AC com transformador elétrico
- Sabão líquido, espuma ou válvula de spray disponíveis
- Capacidade 1 litro

- • Sensore infrarossi
- Funziona con batterie AA (4 unità)
- Alternativa 230V con trasformatore
- Possibilità valvola per sapone liquido, schiuma o spray
- Capacità 1 litro

- ○ • Capteur infrarouge
- Fonctionne avec piles AA (4 unités)
- Alternative 230V AC avec prise courant
- Possibilité valve à savon liquide, mousse ou spray
- Capacité 1 litre

ITEMS

⇒ ○ SECAMANOS ● SECADORES DE MÃOS ● ASCIUGAMANI ◎ SECHE-MAINS



Fuga  

12053.H2

370 x 200 x 223 mm

Bigflow 

12053.H1

370 x 260 x 223 mm

- • Fuga Evo satinado
- Activación mediante sensor láser
- Distancia activación regulable
- Potencia 800 W
- Filtro Hepa
- Tiempo secado 10 - 12 s
- Posibilidad desinfección mediante luz Led UV C

- • Fuga Evo acabado escobado
- Ativado por sensor laser
- Distância de ativação ajustável
- Potência 800 W
- Filtro HEPA
- Tempo de secagem 10-12 s
- Desinfecção com luz LED UV C seleccionável

- • Bigflow Evo satinado
- Activación mediante sensor infrarrojos
- Distancia de activación regulable
- Potencia seleccionable 1200 / 2050 W
- Bajo nivel sonoro
- Posibilidad filtro Hepa
- Tiempo secado 40 s

- • Bigflow Evo acabado escobado
- Ativação do sensor infravermelho
- Distância de ativação ajustável
- Potência seleccionável 1200/2050 W
- Baixo nível de som
- Filtro Hepa disponível
- Tempo de secagem 40 s

- • FUGA Evo satinato
- Attivazione tramite sensore laser
- Distanza attivazione regolabile
- Potenza 800 W
- Filtro Hepa
- Tempo asciugatura 10 - 12 s
- Possibilità disinfezione mediante luce led UV C

- ◎ • Fuga Evo satiné
- Activation par capteur laser
- Distance d'activation réglable
- Puissance 800 W
- Filtre Hepa
- Durée de séchage 10 - 12 s
- Possibilité de désinfection grâce à la LED UV C

- • Bigflow Evo satinato
- Attivazione tramite sensore infrarossi
- Distanza attivazione regolabile
- Potenza selezionabile 1200 / 2050 W
- Basso livello sonoro
- Possibilità filtro Hepa
- Tempo asciugatura 40 s

- ◎ • Bigflow Evo satiné
- Activation par capteur infrarouge
- Distance d'activation réglable
- Puissance sélectionnable 1200 / 2050 W
- Faible niveau sonore
- Possibilité de filtre Hepa
- Durée de séchage 40 s



Fusion 

370 x 200 x 223 mm

12053.H3

- • Fusion
 - Activación mediante sensor láser
 - Salida multijet / blade
 - Distancia activación regulable
 - Potencia regulable 700 900 W
 - Filtro Hepa y Zero Smell
 - Tiempo secado 6 - 12 s
 - Posibilidad desinfección mediante luz Led UV C
- • Fusion
 - Activação mediante sensor láser
 - Saída multijet / blade
 - distancia activação regulable
 - Potencia regulable 700 / 900 W
 - Filtro Hepa e Zero Smell
 - Tempo de secado 6 - 12 s
 - Possibilidade de desinfeção por meio de luz Led UV C
- • Fusion
 - Attivazione tramite sensore laser
 - Uscita multijet / blade
 - Distanza attivazione regolabile
 - Potenza regolabile 700/900 W
 - Filtro Hepa e Zero Smell
 - Tempo asciugatura 6 - 12 s
 - Possibilità disinfezione mediante luce led UV C
- ⦿ • Fusion
 - Activation par capteur laser
 - Sortie multijet/blade
 - Distance d'activation réglable
 - Puissance réglable 700 900 W
 - Filtre Hepa et Zero Smell
 - Temps de séchage 6 - 12 s
 - Possibilité de désinfection grâce à la LED UV C

ITEMS

- DISPENSADORES DE PAPEL TOALLA DISPENSADORES DE PAPEL TOALLA DISPENSER DI CARTA DISTRIBUTEURS DE PAPIER ESSUIE-MAINS



Automatic paper

12053.PA

370 x 350 x 223 mm

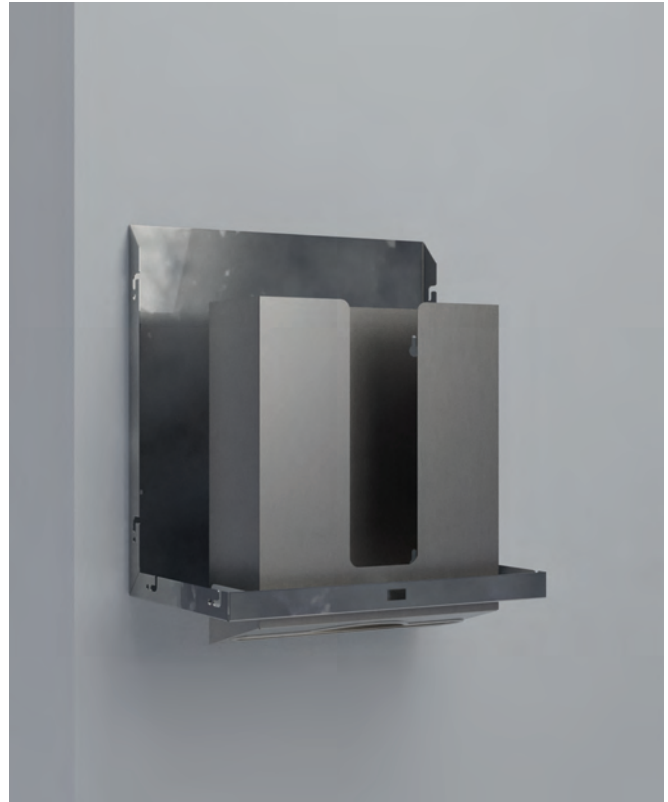

Manual paper

12053.P

370 x 350 x 223 mm

- Sensor por humedad
- Funciona con baterías tipo D (4 unidades)
- Alternativa 230V AC con transformador
- Rollo de papel continuo Ø 200 x 220 mm de ancho
- Salida automática, corte manual
- Sensore per umidità
- Funziona con batterie tipo D (4 unità)
- Alternativa 230V AC con trasformatore
- Rotolo di carta continuo Ø 200 x 220 mm di larghezza
- Uscita automatica, taglio manuale

- Sensor de umidade
- Funciona com baterias tipo D (4 unidades)
- Alternativa 230V AC com transformador
- Rolo de papel continuo Ø 200 x 220 mm de largo
- Saída automática, corte manual
- Capteur d'humidité
- Fonctionne avec piles type D (4 unités)
- Alternative 230V AC avec prise courant
- Rouleau de papier continu Ø 200 x 220 mm de large
- Sortie automatique, découpe manuelle

- Capacidad 400/600 unidades

- Capacidade 400/600 unidades

- Capacità 400/600 unità

- Capacité 400/600 unités

○ SEPARADORES ● SEPARADORES ● SEPARATORI ⊙ SÉPARATEURS



5

98416.05

370 x 50 x 223 mm



10

98416.10

370 x 100 x 223 mm



15

98416.15

370 x 150 x 223 mm

- • Separadores de acero inoxidable AISI 304
• Resistente a la corrosión
- • Separadores de aço inoxidável AISI 304
• Resistente a corrosão
- • Separatori in acciaio inox AISI 304
• Resistente alla corrosione
- ⊙ • Séparateurs en acier inoxydable AISI 304
• Résistant à la corrosion

ITEM PACKS

VELOX

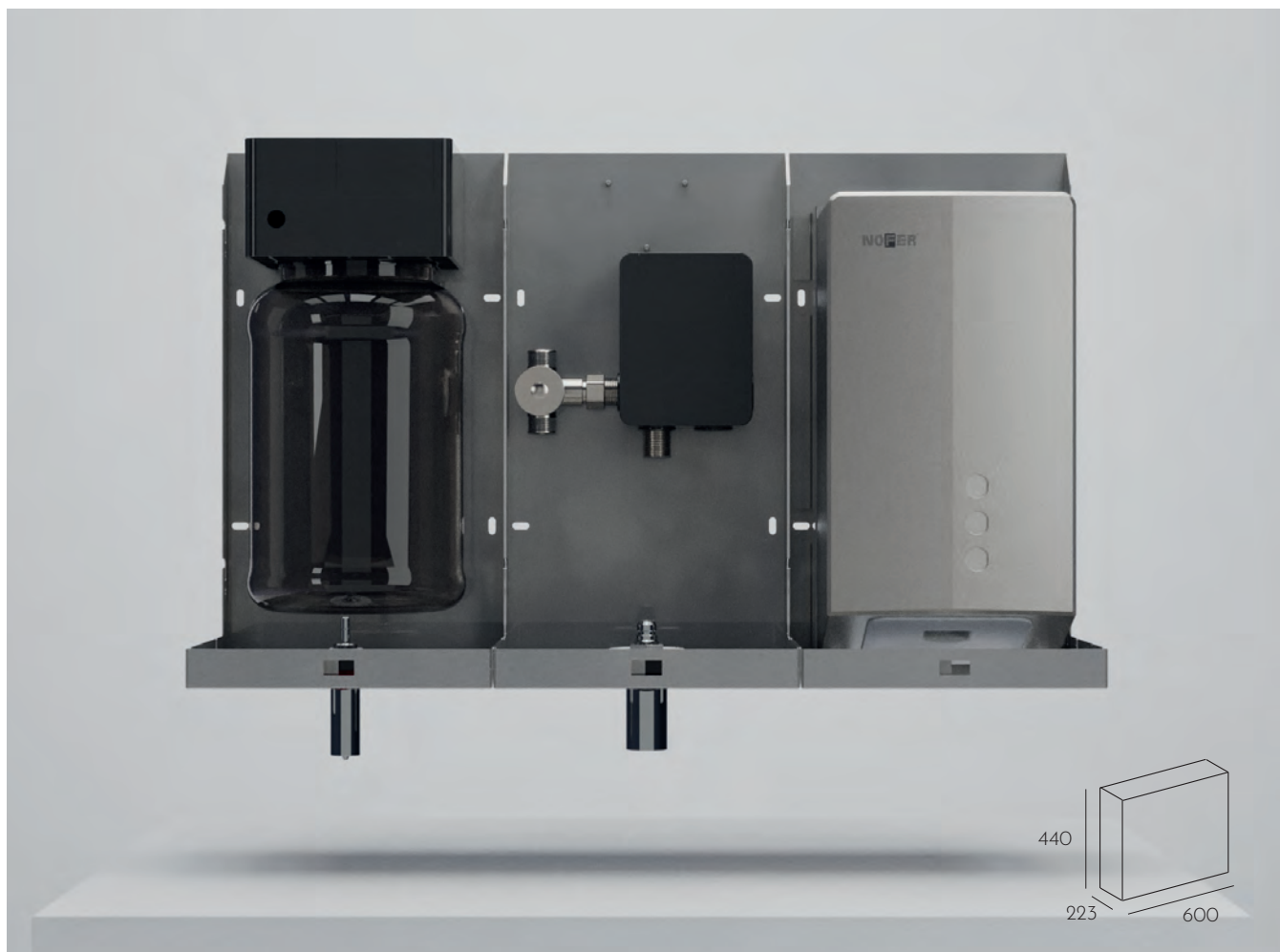

Laser Soap + Laser Faucet + Fuga Evo

ITEM	• Capacidad • Capacidade • Capacità • Capacité	• Potencia • Power • Potenza • Puissance	• Nivel sonoro • Nivel de som • Livello sonoro • Niveau sonore	• Sensor • Sensor • Sensore • Capteur	• Regulación (distancia) • Regulação (distancia) • Regolazione (distanza) • Réglage (distance)	• Voltaje / Frecuencia • Voltagem / Frequência • Voltaggio / Frequenza • Voltage / Fréquence
Laser Faucet	3 / 1,89 l/min	-	-	Laser	●	220 AC 50 - 60 Hz
Laser Soap	1,5 - 3 l	-	-	Laser	●	220 AC 50 - 60 Hz
Fuga Evo	-	800 W	72 dBA	Laser	●	220 - 240 V 50 - 60 Hz

○ La imagen del producto figura solamente a título informativo, la correcta instalación deberá incluir las conexiones entre los elementos

● As imagens dos produtos fornecidas são apenas para fins informativos, a instalação deve incluir as conexões entre os elementos

● Le immagini dei prodotti fornite sono solo a scopo informativo, l'installazione deve includere le connessioni tra gli elementi

◎ Les images des produits fournies sont à titre indicatif seulement, l'installation doit inclure les connexions entre les éléments

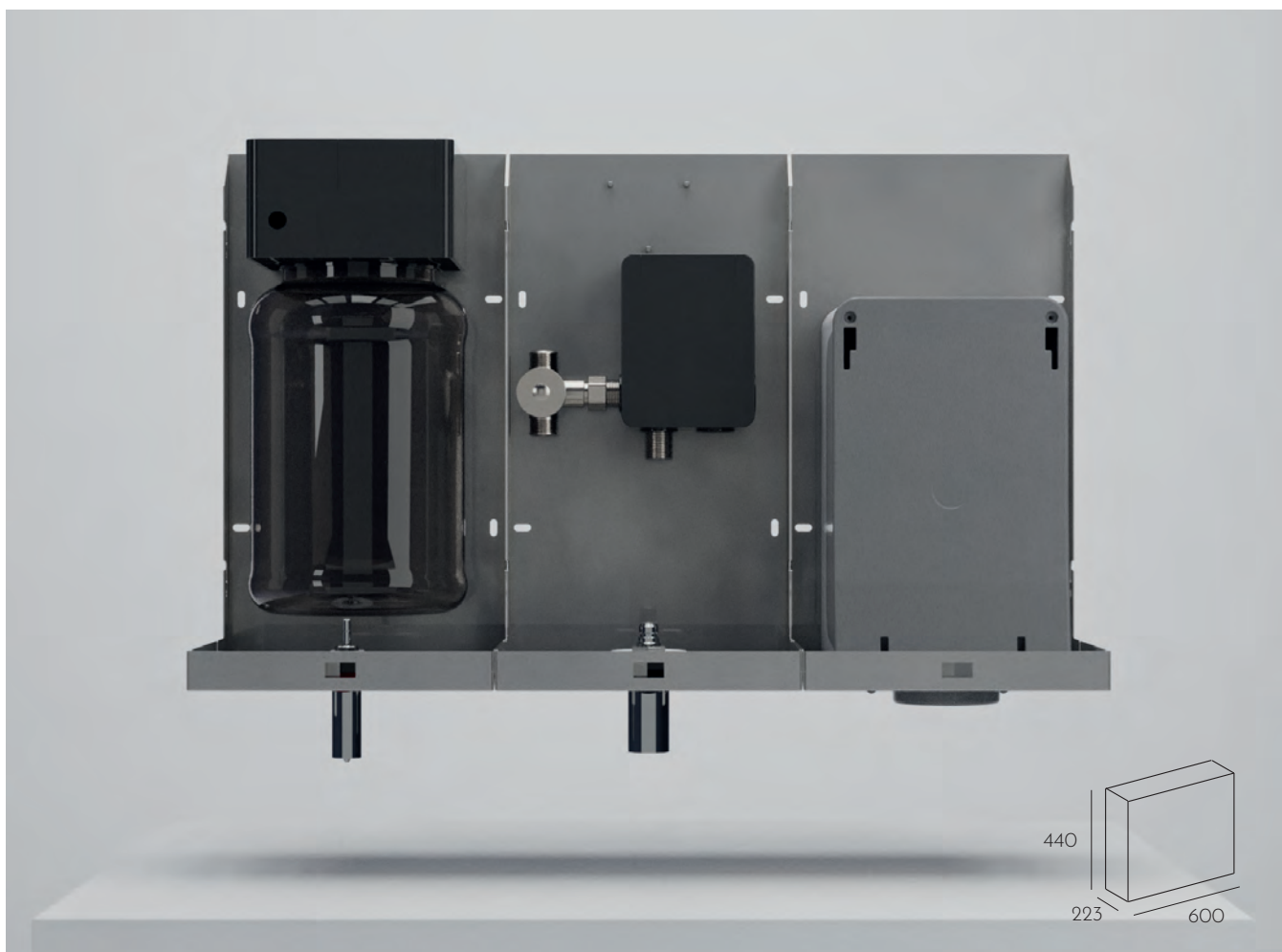

Laser Soap + Laser Faucet + Fusion

ITEM	<ul style="list-style-type: none"> • Capacidad • Capacidade • Capacità • Capacité 	<ul style="list-style-type: none"> • Potencia • Power • Potenza • Puissance 	<ul style="list-style-type: none"> • Nivel sonoro • Nível de som • Livello sonoro • Niveau sonore 	<ul style="list-style-type: none"> • Sensor • Sensor • Sensore • Capteur 	<ul style="list-style-type: none"> • Regulación (distancia) • Regulação (distancia) • Regolazione (distanza) • Réglage (distance) 	<ul style="list-style-type: none"> • Voltaje / Frecuencia • Voltagem / Frequência • Voltaggio / Frequenza • Voltage / Fréquence
Laser Faucet	3 / 1,89 l/min	-	-	Laser	●	220 AC 50 - 60 Hz
Laser Soap	1,5 - 3 l	-	-	Laser	●	220 AC 50 - 60 Hz
Fusion	-	700 - 900 W	66 dBA	Laser	●	220 - 240 V 50 - 60 Hz

○ La imagen del producto figura solamente a título informativo, la correcta instalación deberá incluir las conexiones entre los elementos

● As imagens dos produtos fornecidas são apenas para fins informativos, a instalação deve incluir as conexões entre os elementos

● Le immagini dei prodotti fornite sono solo a scopo informativo, l'installazione deve includere le connessioni tra gli elementi



○ Les images des produits fournies sont à titre indicatif seulement, l'installation doit inclure les connexions entre les éléments

ITEM PACKS

VELOX shared



Laser Soap x2 + Laser Faucet x 2 + Fuga Evo

ITEM	• Capacidad • Capacidade • Capacità • Capacité	• Potencia • Power • Potenza • Puissance	• Nivel sonoro • Nivel de som • Livello sonoro • Niveau sonore	• Sensor • Sensor • Sensore • Capteur	• Regulación (distancia) • Regulação (distancia) • Regolazione (distanza) • Réglage (distance)	• Voltaje / Frecuencia • Voltagem / Frequência • Voltaggio / Frequenza • Voltage / Fréquence
 Laser Faucet x2	3 / 1,89 l/min	-	-	Laser	●	220 AC 50 - 60 Hz
 Laser Soap x2	1,5 - 3 l	-	-	Laser	●	220 AC 50 - 60 Hz
 Fuga Evo	-	800 W	72 dBA	Laser	●	220 - 240 V 50 - 60 Hz

○ La imagen del producto figura solamente a título informativo, la correcta instalación deberá incluir las conexiones entre los elementos

● As imagens dos produtos fornecidas são apenas para fins informativos, a instalação deve incluir as conexões entre os elementos

● Le immagini dei prodotti fornite sono solo a scopo informativo, l'installazione deve includere le connessioni tra gli elementi

◎ Les images des produits fournies sont à titre indicatif seulement, l'installation doit inclure les connexions entre les éléments

SUPRA shared

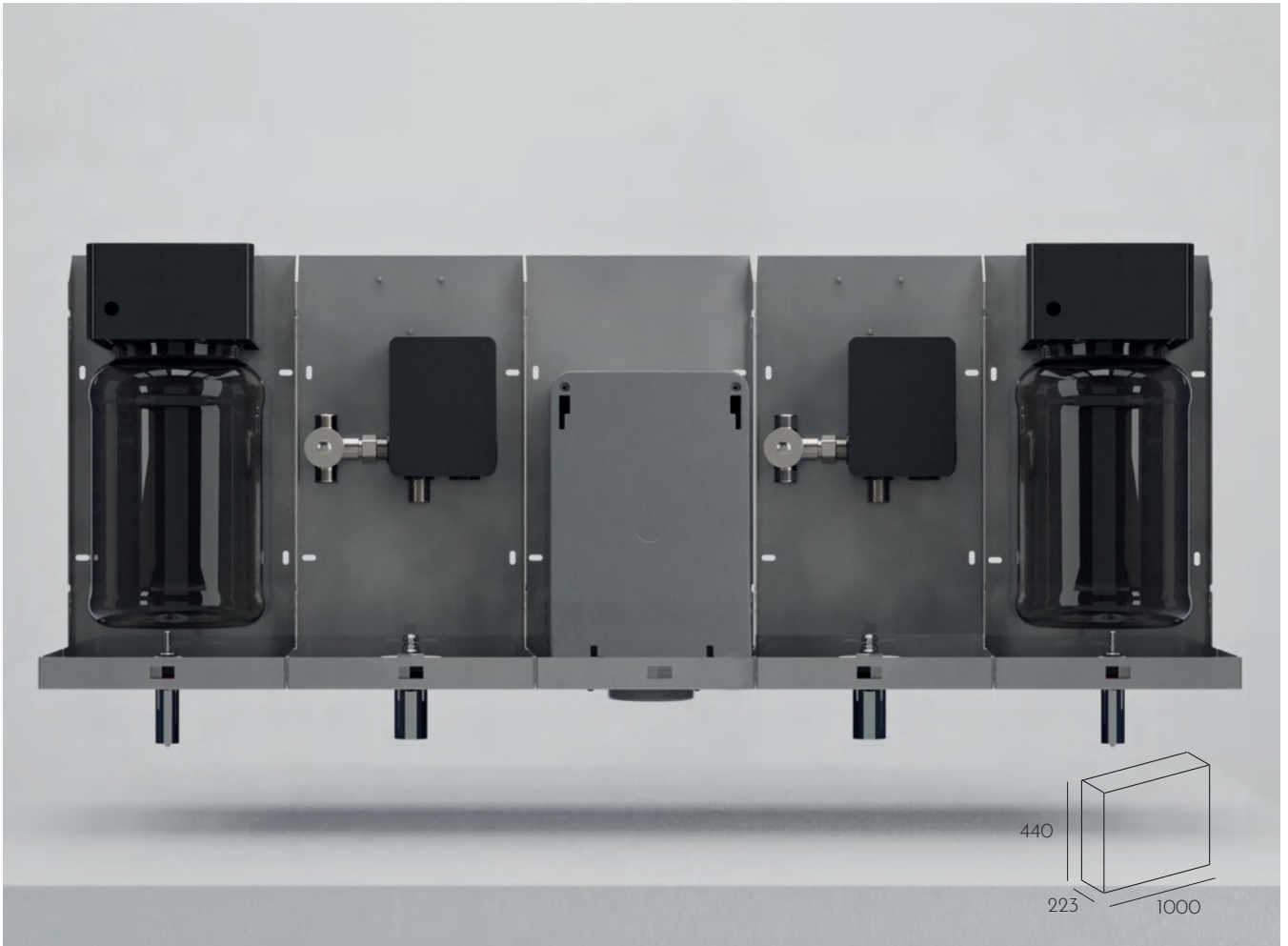

Laser Soap x2 + Laser Faucet x2 + Fusion

ITEM	• Capacidad • Capacidade • Capacità • Capacité	• Potencia • Power • Potenza • Puissance	• Nivel sonoro • Nível de som • Livello sonoro • Niveau sonore	• Sensor • Sensor • Sensore • Capteur	• Regulación (distancia) • Regulação (distancia) • Regolazione (distanza) • Réglage (distance)	• Voltaje / Frecuencia • Voltagem / Frequência • Voltaggio / Frequenza • Voltage / Fréquence
Laser Faucet x2	3 / 1,89 l/min	-	-	Laser	●	220 AC 50 - 60 Hz
Laser Soap x2	1,5 - 3 l	-	-	Laser	●	220 AC 50 - 60 Hz
Fusion	-	700 - 900 W	66 dBA	Laser	●	220 - 240 V 50 - 60 Hz

○ La imagen del producto figura solamente a título informativo, la correcta instalación deberá incluir las conexiones entre los elementos

● As imagens dos produtos fornecidas são apenas para fins informativos, a instalação deve incluir as conexões entre os elementos

● Le immagini dei prodotti fornite sono solo a scopo informativo, l'installazione deve includere le connessioni tra gli elementi

○ Les images des produits fournies sont à titre indicatif seulement, l'installation doit inclure les connexions entre les éléments

ITEM PACKS

TOWEL



CE

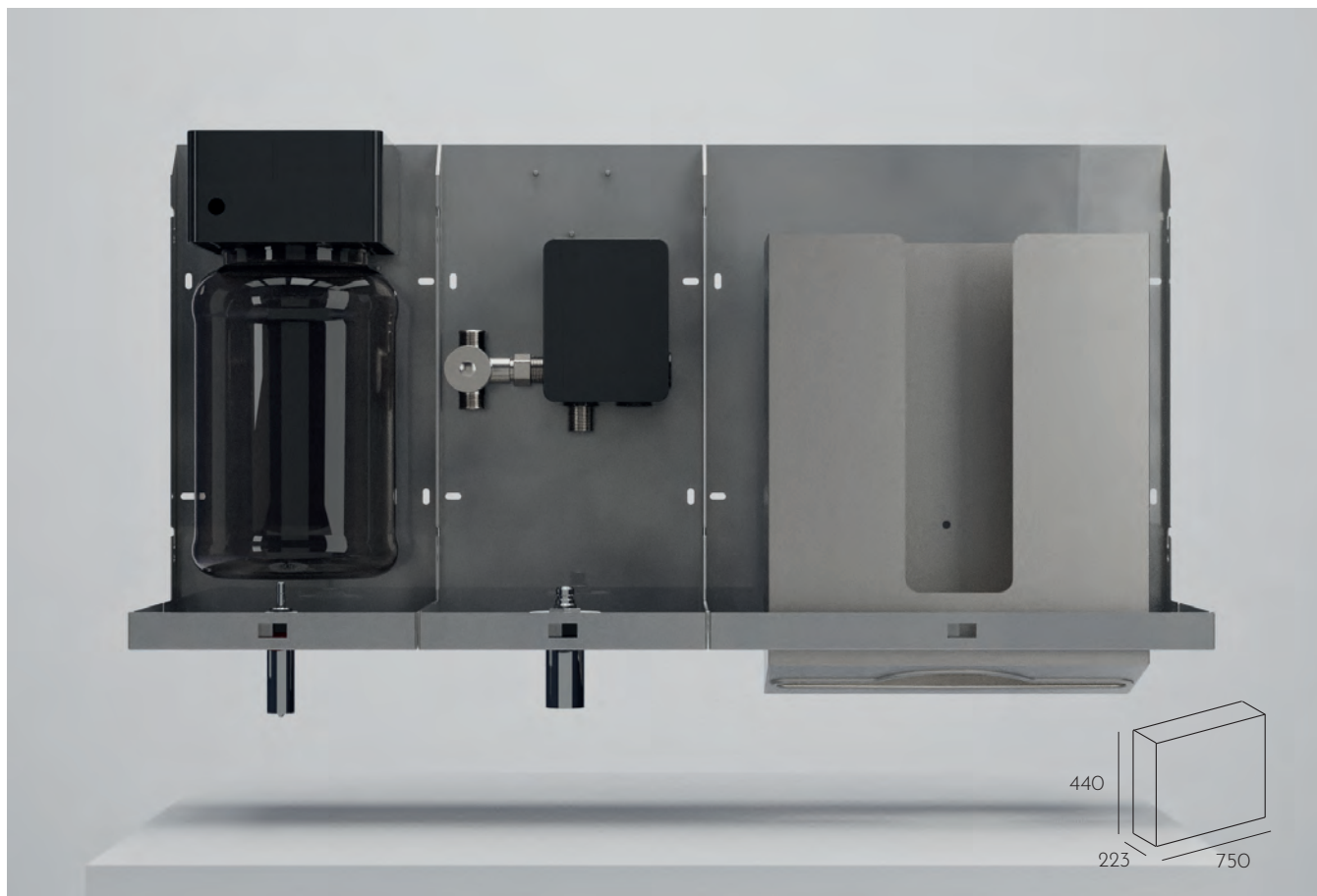

Laser Soap + Laser Faucet + Manual Paper

ITEM	• Capacidad • Capacidade • Capacità • Capacité	• Sensor • Sensor • Sensore • Capteur	• Regulación (distancia) • Regulação (distancia) • Regolazione (distanza) • Réglage (distance)	• Voltaje / Frecuencia • Voltagem / Frequência • Voltaggio / Frequenza • Voltage / Fréquence
 Laser Faucet	3 / 1,89 l/min	Laser	●	220 - 240 V 50 - 60 Hz
 Laser Soap	1,5 - 3 l	Laser	●	220 - 240 V 50 - 60 Hz
 Manual paper	400 - 600	-	-	-

○ La imagen del producto figura solamente a título informativo, la correcta instalación deberá incluir las conexiones entre los elementos

● As imagens dos produtos fornecidas são apenas para fins informativos, a instalação deve incluir as conexões entre os elementos

● Le immagini dei prodotti fornite sono solo a scopo informativo, l'installazione deve includere le connessioni tra gli elementi

◎ Les images des produits fournies sont à titre indicatif seulement, l'installation doit inclure les connexions entre les éléments

AUTOTOWEL

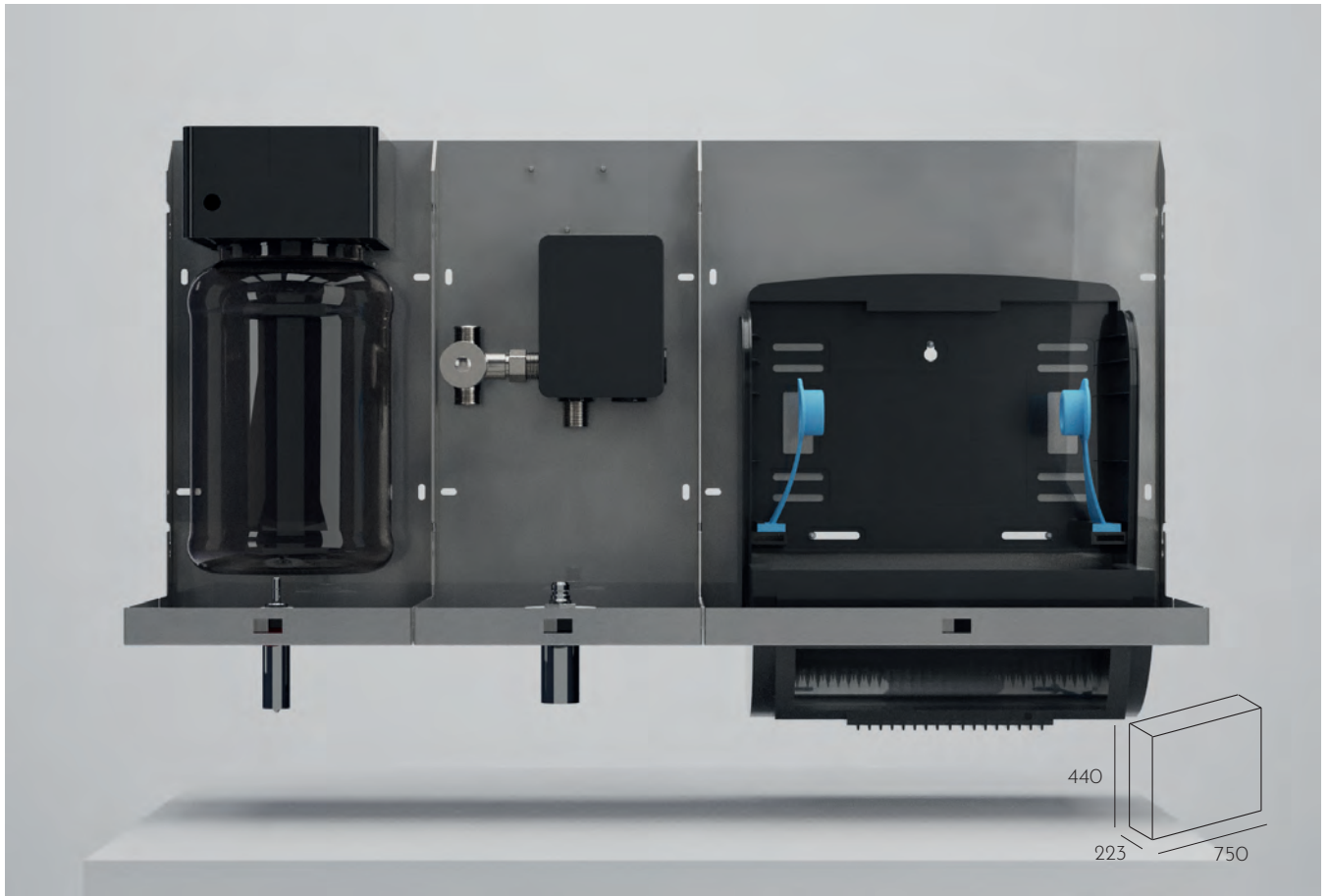

Laser Soap + Laser Faucet + Automatic Paper

ITEM	<ul style="list-style-type: none"> • Capacidad • Capacidade • Capacità • Capacité 	<ul style="list-style-type: none"> • Sensor • Sensor • Sensore • Capteur 	<ul style="list-style-type: none"> • Regulación (distancia) • Regulação (distancia) • Regolazione (distanza) • Réglage (distance) 	<ul style="list-style-type: none"> • Voltaje / Frecuencia • Voltagem / Frequência • Voltaggio / Frequenza • Voltage / Fréquence
Laser Faucet	3 / 1,89 l/min	Laser	●	220 - 240 V 50 - 60 Hz
Laser Soap	1,5 - 3 l	Laser	●	220 - 240 V 50 - 60 Hz
Automatic paper	200 x 220	IR	-	230 V Ac

- La imagen del producto figura solamente a título informativo, la correcta instalación deberá incluir las conexiones entre los elementos
- As imagens dos produtos fornecidas são apenas para fins informativos, a instalação deve incluir as conexões entre os elementos
- Le immagini dei prodotti fornite sono solo a scopo informativo, l'installazione deve includere le connessioni tra gli elementi
- Les images des produits fournies sont à titre indicatif seulement, l'installation doit inclure les connexions entre les éléments

ITEM PACKS

BASIC

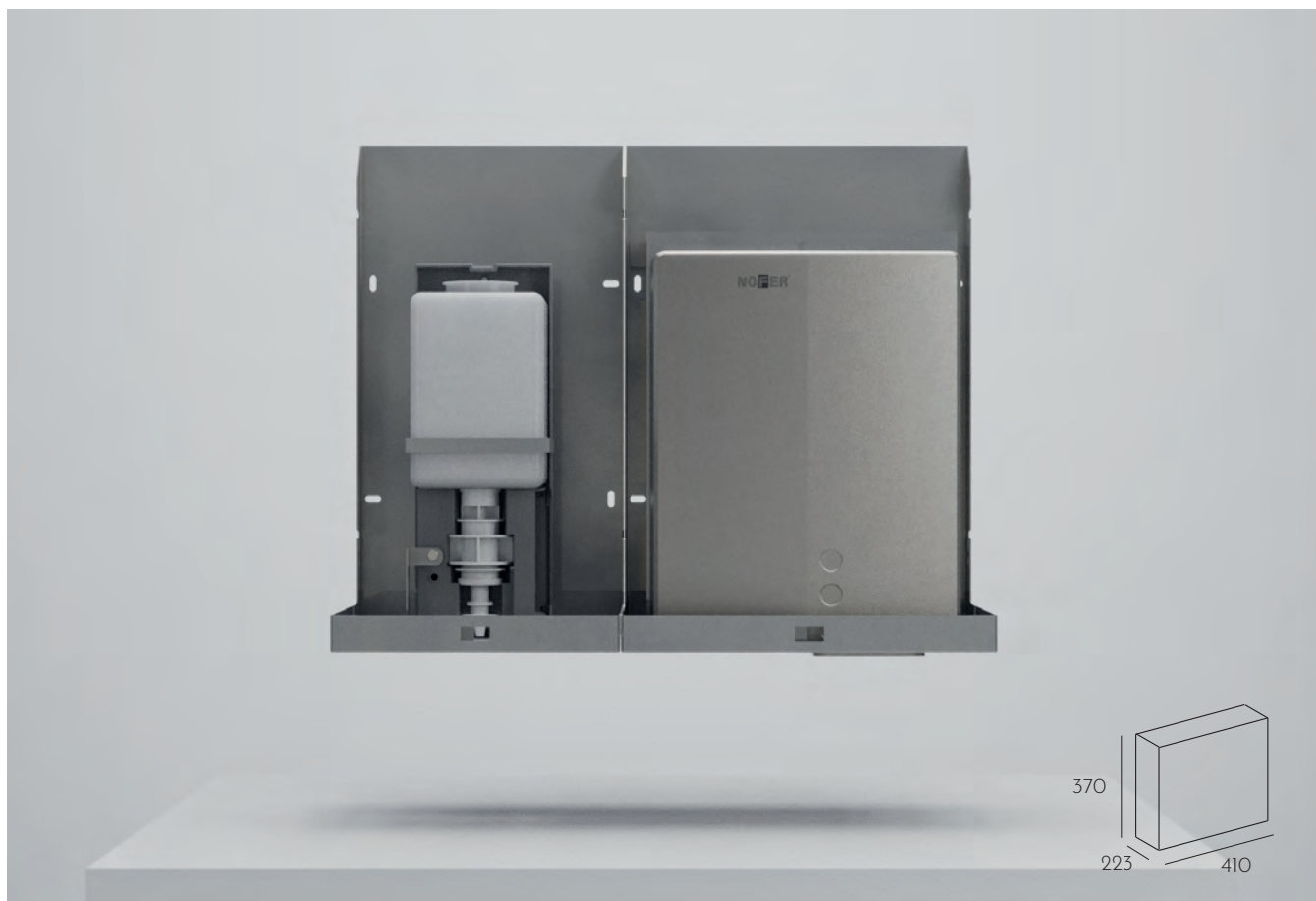

Automatic Soap + Bigflow Evo

ITEM	• Capacidad • Capacidade • Capacità • Capacité	• Potencia • Power • Potenza • Puissance	• Nivel sonoro • Nivel de som • Livello sonoro • Niveau sonore	• Sensor • Sensor • Sensore • Capteur	• Regulación (distancia) • Regulação (distancia) • Regolazione (distanza) • Réglage (distance)	• Voltaje / Frecuencia • Voltagem / Frequência • Voltaggio / Frequenza • Voltage / Fréquence
Automatic Soap	1000 ml	-	-	IR	-	220 - 12 V
Bigflow Evo	-	1200 - 2050 W	60 dBA	IR	-	220 - 240 V 50 - 60 Hz



○ La imagen del producto figura solamente a título informativo, la correcta instalación deberá incluir las conexiones entre los elementos

● As imagens dos produtos fornecidas são apenas para fins informativos, a instalação deve incluir as conexões entre os elementos

● Le immagini dei prodotti fornite sono solo a scopo informativo, l'installazione deve includere le connessioni tra gli elementi

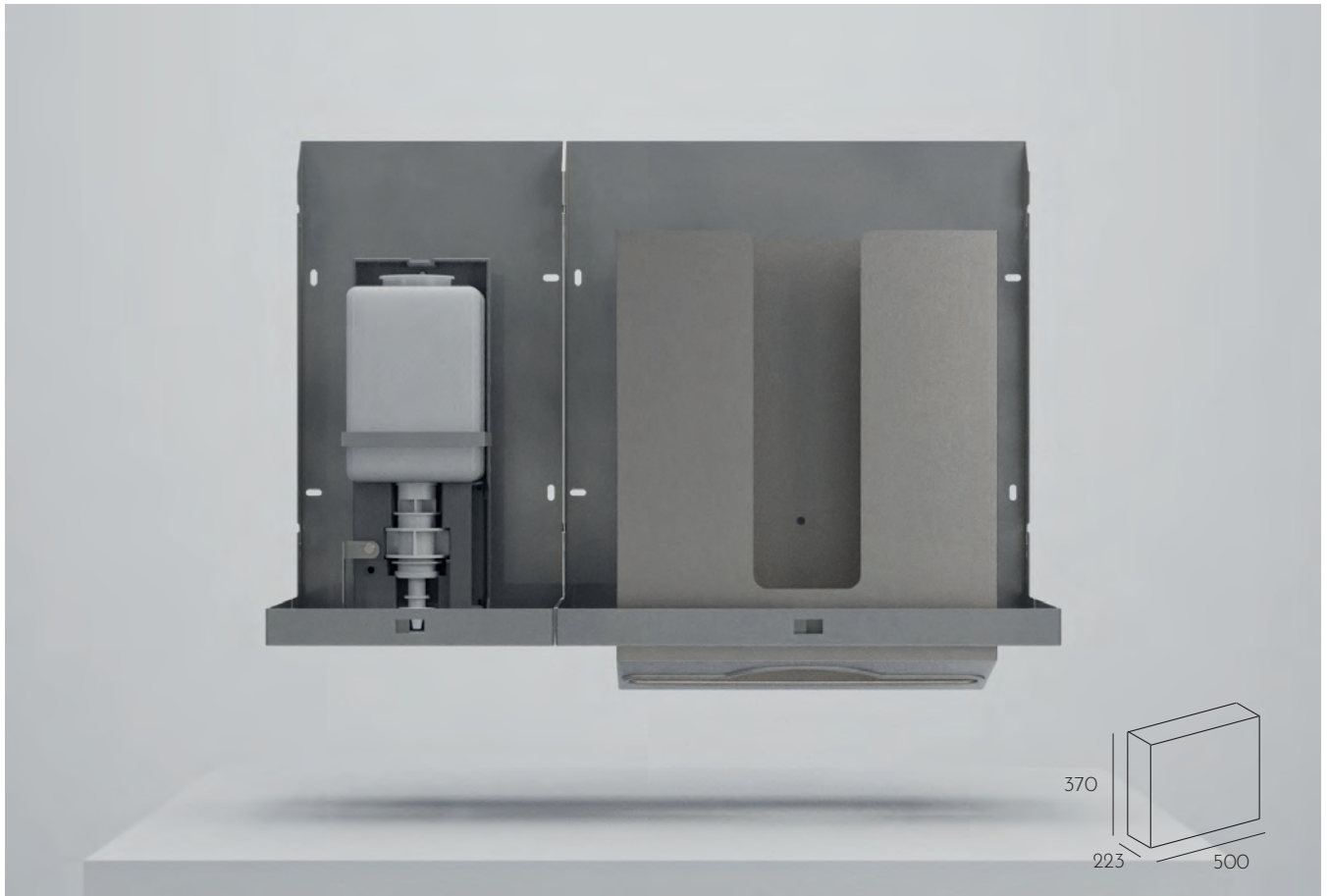
◎ Les images des produits fournies sont à titre indicatif seulement, l'installation doit inclure les connexions entre les éléments



Automatic Soap + Manual Paper

ITEM	<ul style="list-style-type: none"> • Capacidad • Capacidade • Capacità • Capacité 	<ul style="list-style-type: none"> • Sensor • Sensor • Sensore • Capteur 	<ul style="list-style-type: none"> • Regulación (distancia) • Regulação (distancia) • Regolazione (distanza) • Réglage (distance) 	<ul style="list-style-type: none"> • Voltaje / Frecuencia • Voltagem / Frequência • Voltaggio / Frequenza • Voltage / Fréquence
 Automatic Soap	1000 ml	IR	-	220 - 12 V
 Manual paper	400 - 600	-	-	-

- La imagen del producto figura solamente a título informativo, la correcta instalación deberá incluir las conexiones entre los elementos
- As imagens dos produtos fornecidas são apenas para fins informativos, a instalação deve incluir as conexões entre os elementos
- Le immagini dei prodotti fornite sono solo a scopo informativo, l'installazione deve includere le connessioni tra gli elementi
- ⦿ Les images des produits fournies sont à titre indicatif seulement, l'installation doit inclure les connexions entre les éléments

PLUG & PLAY   

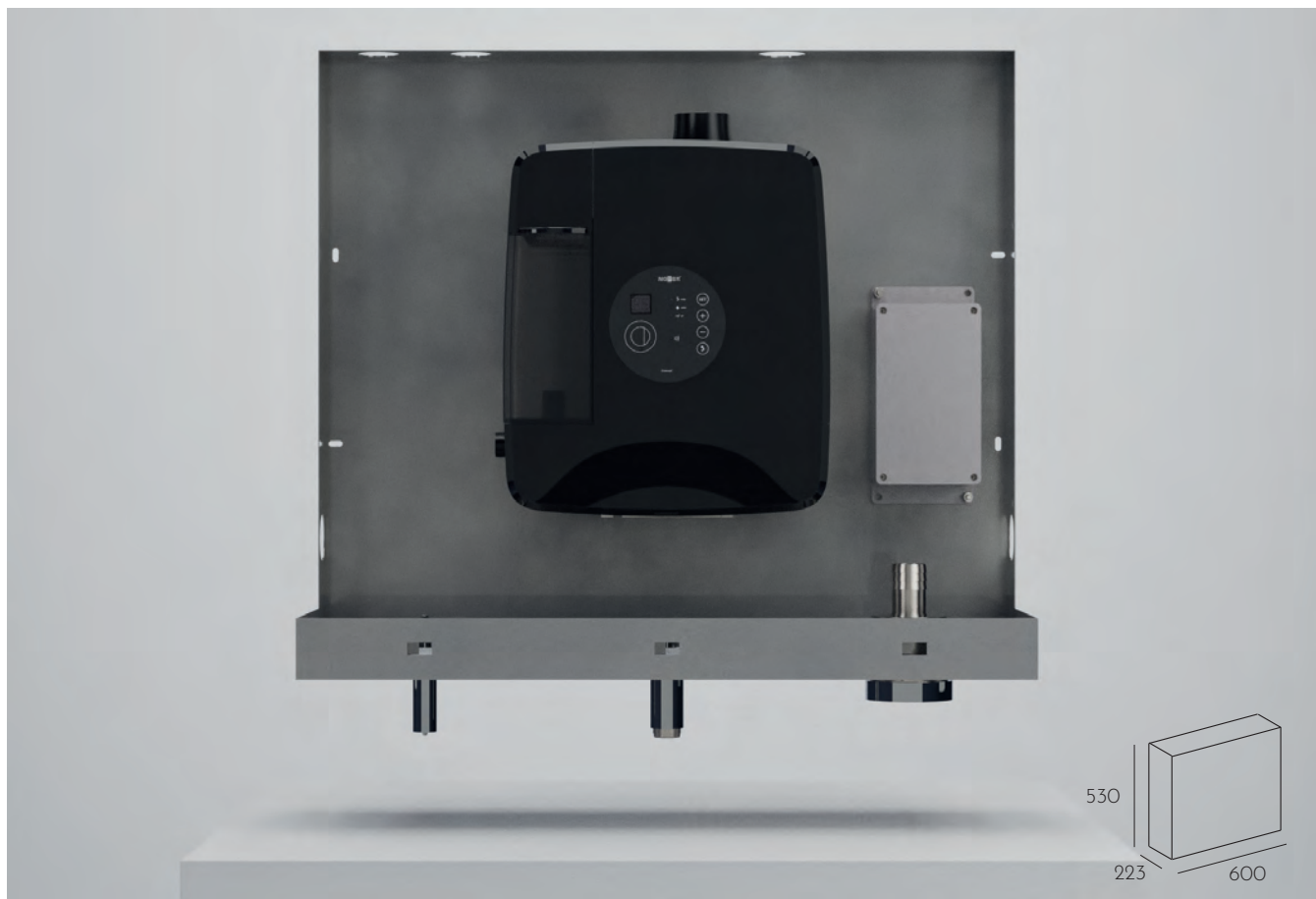

Concept³

12053.CTS

ITEM	• Capacidad • Capacidade • Capacità • Capacité	• Potencia • Power • Potenza • Puissance	• Nivel sonoro • Nivel de som • Livello sonoro • Niveau sonore	• Sensor • Sensor • Sensore • Capteur	• Regulación (distanza) • Regulação de distancia) • Regolazione (distanza) • Réglage (distance)	• Voltaje / Frecuencia • Voltagem / Frequência • Voltaggio / Frequenza • Voltage / Fréquence
	3-7 l/min (3 bar)					
 Concept ³	2 l	1200 W	65 dBA	IR	●	5 V
	-					220 - 240 V 50 - 60 Hz

○ La imagen del producto figura solamente a título informativo, la correcta instalación deberá incluir las conexiones entre los elementos

● As imagens dos produtos fornecidas são apenas para fins informativos, a instalação deve incluir as conexões entre os elementos

● Le immagini dei prodotti fornite sono solo a scopo informativo, l'installazione deve includere le connessioni tra gli elementi

◎ Les images des produits fournies sont à titre indicatif seulement, l'installation doit inclure les connexions entre les éléments



MUMO & SKIN



ITEM



Laser
Faucet



Laser Soap



Automatic
Soap



Fuga Evo



Bigflow Evo



Fusion



Automatic
paper



Manual
paper



5 - 10 - 15

Personaliza la combinación que más se adecue a tu necesidad

Personalize a combinação que melhor se adapta às suas necessidades

Personalizza la combinazione più adatta alle tue esigenze

Personnalisez la combinaison la mieux adaptée à vos besoins

- Recubre la funcionalidad de tu MUMO con un mueble de diseño minimalista y elegante
- Revista a funcionalidade do seu MUMO com uma peça de mobília elegante e minimalista
- Rivesti la funzionalità del tuo MUMO con un mobile dal design elegante e minimalista
- ⦿ Recouvrez la fonctionnalité de votre MUMO avec un meuble au design minimaliste et élégant

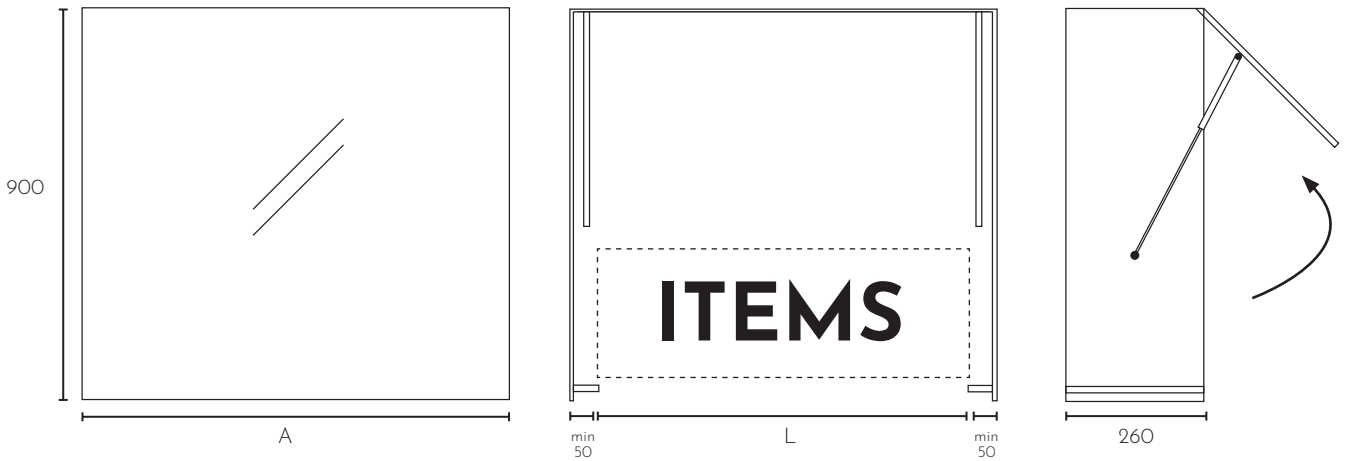

A (mm) ITEMS + SKIN

700	ITEMS L ≤ 600	12055.070							
800	ITEMS L ≤ 700	12055.080	BASIC L = 410	ESSENTIA L = 500	VELOX L = 600	SUPRA L = 600	PLUG&PLAY L = 600		
900	ITEMS L ≤ 800	12055.090							
1000	ITEMS L ≤ 900	12055.100	BASIC L = 410	ESSENTIA L = 500	VELOX L = 600	SUPRA L = 600	PLUG&PLAY L = 600	TOWEL L = 750	AUTOTOWEL L = 750
1200*	ITEMS L ≤ 1100	12055.120	BASIC x2 L = 820	ESSENTIA x2 L = 1000	VELOX shared L = 1000	SUPRA shared L = 1000			

*Lavabos para 2 usuarios

*Lavatórios para 2 usuarios

*Lavelli per 2 utenti

*Lavabos pour 2 utilisateurs

MUMO & SKIN

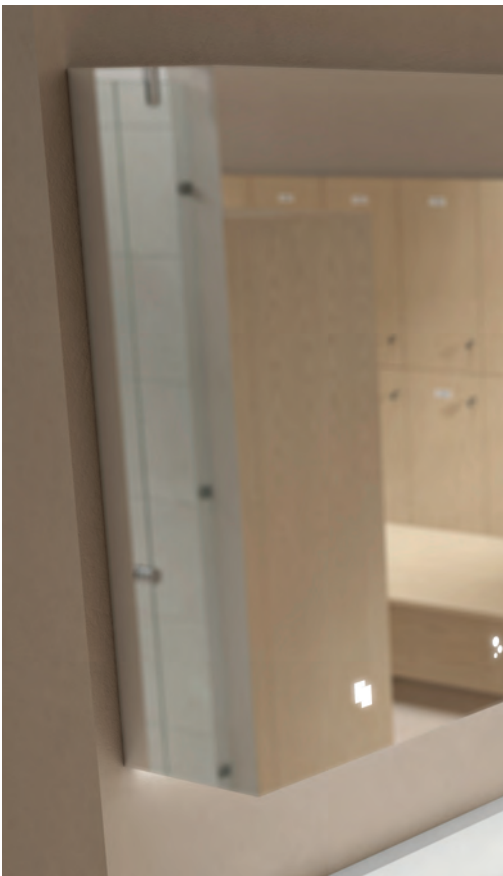

EXTRA



- LED. Iluminación perimetral inferior a lo largo de todo el mueble
- LED. Iluminação de perímetro inferior em toda a unidade
- LED. Illuminazione perimetrale inferiore in tutta l'unità
- LED. Éclairage du périmètre inférieur le long de tout le meuble

	MUMO 700	MUMO 800	MUMO 900	MUMO 1000	MUMO 1200
<input type="radio"/> LED frontal para mueble <input type="radio"/> LED frontal para móvel <input type="radio"/> LED frontale per mobili <input type="radio"/> LED avant pour meuble	90524.0700F	90524.0800F	90524.0900F	90524.1000F	90524.1200F
<input type="radio"/> LED trasero para mueble <input type="radio"/> LED traseiro para móvel <input type="radio"/> LED posteriore per mobili <input type="radio"/> LED arrière pour meuble	90524.0700T	90524.0800T	90524.0900T	90524.1000T	90524.1200T
<input type="radio"/> Conjunto LED trasero y frontal para mueble <input type="radio"/> Conjunto LED traseiro e frontal para móvel <input type="radio"/> Montaggio LED posteriore e frontale per mobili <input type="radio"/> LED arrière et avant pour meuble	90524.0700TF	90524.0800TF	90524.0900TF	90524.1000TF	90524.1200TF



- Cierre de seguridad incluido. Para reposiciones, mantenimiento
- Trava de segurança incluída para substituições, manutenção
- Chiusura di sicurezza inclusa. Per sostituzioni, manutenzioni
- Verrouillage de sécurité. Pour reconstitutions, entretien



- Lateral espejo. Añade profundidad al conjunto
- Espelho lateral. Adicione profundidade ao todo
- Specchietto laterale. Aggiungi profondità al tutto
- Miroir latéral. Accentue profondeur à l'ensemble

90484.LAT



- Regleta de ajuste vertical con espejo. Adaptar MUMO a cualquier ambiente y necesidades
- Tira de ajuste vertical com espelho. Adapte o MUMO a qualquer ambiente e necessidade
- Presa elettrica multipla con specchio. Adatta MUMO a qualsiasi ambiente ed esigenza
- Élément latéral de finition vertical avec miroir. Adapter MUMO à tout environnement et besoins

98589

YOUR MUMO +

○ ENCIMERAS ● BANCADAS ● PIANI LAVABO ● PLAN DE TRAVAIL



Solid Surface

DECOSAN

- Solid Surface es un material compuesto por dos terceras partes de minerales naturales y resinas. Material no poroso, antibacteriano, sedoso y cálido al tacto

Personalizable según necesidades del cliente

- Solid Surface è un materiale composto per due terzi da minerali naturali e resine. Materiale non poroso, antibatterico, setoso e caldo al tatto

Personalizzabile in base alle esigenze del cliente

- Solid Surface é um material composto por dois terços dos minerais natural e resinas. Material antibacteriano não poroso, sedoso e quente ao toque

Customizável de acordo com as necessidades do cliente

- Solid Surface est un matériau composé de deux tiers de minéraux naturels et de résines. Matériau non poreux, antibactérien, soyeux et doux au toucher.

Personnalisable selon les besoins du client



Inox

NOFER®

- Lavamanos de acero inoxidable AISI 304, con fijación a pared. Resistente a la corrosión y apto para colectividades, Personalizable según necesidades del cliente
- Lavatório em aço inox AISI 304, com fixação mural. Resistente à corrosão e adequado para locais públicos. Customizável de acordo com as necessidades do cliente
- Lavabo in acciaio inox AISI 304, con fissaggio a parete. Resistente alla corrosione e adatto per luoghi pubblici. Personalizzabile in base alle esigenze del cliente
- ◎ Lavabo en acier inox AISI 304, avec fixation murale. Résistant à la corrosion et adapté aux collectivités, Personnalisable selon les besoins du client

◀ TENNIS
COURTS





- **GRIFERÍA
ELECTRÓNICA**
- **TORNEIRA
ELETRÔNICA**
- **RUBINETTERIA
ELETTRONICA**
- ⦿ **ROBINET
ÉLECTRONIQUE**



○ GRIFERÍA LÁSER

● TORNEIRAS LASER

● RUBINETTI LASER

◎ ROBINETS LASER





Grifería láser

Cuerpo de latón CW617N cromado. Componentes plásticos en POM

Activación mediante sensor láser

Temperatura máxima 85° C. Temperatura máxima recomendada 60° C

Presión de trabajo entre 0,5-6 bar. Presión recomendada 3 bar

Aireador plástico anti cal y filtro antipartículas

Disponibles versiones estándar 6 l/min, ECO 3 l/min y LEED 1,89 l/min

Alimentación mediante batería recargable o corriente eléctrica



Torneiras laser

Corpo em latão cromado CW617N. Componentes plásticos em POM

Ativação por sensor laser

Temperatura máxima 85° C. Temperatura máxima recomendada 60° C

Pressão de trabalho entre 0,5-6 bar. Pressão recomendada 3 bar

Aerador de plástico anti-calcário e filtro anti-partículas

Versões standards disponíveis 6 l/min, ECO 3 l/min e LEED 1,89 l/min

Alimentado por baterias ou corrente elétrica



Rubinetteria laser

Corpo in ottone CW617N cromato. Componenti in plastica in POM

Attivazione sensore laser

Temperatura massima 85° C. Temperatura massima consigliata 60° C

Pressione di esercizio tra 0,5-6 bar. Pressione consigliata 3 bar

Aeratore anticalcare in plastica e filtro antiparticolato

Versioni standard disponibili 6 l/min, ECO 3 l/min e LEED 1,89 l/min

Alimentato da batterie ricaricabili o corrente elettrica



Robinet laser

Corps en laiton CW617N chromé. Composant plastiques en POM

Déclenchement par capteur laser

Température maximale 85° C. Température maximale recommandée 60° C

Pression de fonctionnement entre 0.5-6 bar. Pression recommandée 3 bars

Aérateur en plastique anticalcaire et filtre antiparticules

Disponibles en versions standard 6 l/min, ECO 3 l/min et LEED 1,89 l/min

Alimenté par batteries rechargeables ou du courant électrique

○ DISPONIBILIDAD DE COLORES EN GRIFERÍA LÁSER

● DISPONIBILIDADE DE CORES EM TORNEIRAS A LASER

● DISPONIBILITÀ DI COLORI IN RUBINETTERIA LASER

⊙ DISPONIBILITÉ DE COULEURS EN ROBINETTERIE LASER

○ Brillo ● Brillante ● Lucido ● Brillant

○ Dorado ● Dourado ● Dorato ● Doré

○ Satinado ● Acetinado ● Satinato ● Satiné

○ Negro ● Preto ● Nero ● Noir



○ Grifería electrónica

● Torneira eletrônica

● Rubinetteria elettronica

◎ Robinet électronique



07362.220.LB

Laserlux

PROXIMAMENTE
COMING SOON

NEW • NUEVO
NOUVEAU • NUOVO

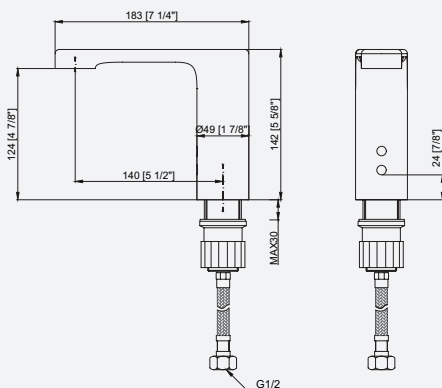

○ Grifo electrónico para lavabo encimera. Activación por sensor láser. Alimentación por baterías o corriente eléctrica

● Rubinetto elettronico per bordo lavabo. Attivazione per sensore laser. Alimentato da batterie o corrente elettrica

● Torneira eletrônica para lavatório de bancada. Ativação por sensor laser. Alimentado por baterias ou corrente elétrica

◎ Robinet électronique de lavabo installation sur plan de travail. Déclenchement par capteur laser. Alimenté par batteries ou du courant électrique



07362.220.LB
225,00 €

07362.LB
270,00 €



07362.220.EB
230,00 €

07362.EB
275,00 €



07362.220.B
225,00 €

07362.B
270,00 €



07362.220.LN

Laserlux

PROXIMAMENTE
COMING SOON

NEW • NUEVO
NOUVEAU • NUOVO

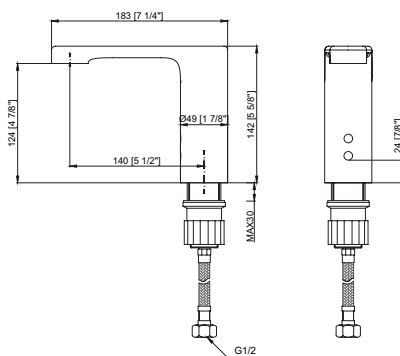

○ Grifo electrónico para lavabo encimera. Activación por sensor láser. Alimentación por baterías o corriente eléctrica

● Rubinetto elettronico per bordo lavabo. Attivazione per sensore laser. Alimentato da batterie o corrente elettrica

● Torneira eletrônica para lavatório de bancada. Ativação por sensor laser. Alimentado por baterias ou corrente elétrica

◎ Robinet électronique de lavabo installation sur plan de travail. Déclenchement par capteur laser. Alimenté par batteries ou du courant électrique



07362.220.LN
247,50 €

07362.LN
297,00 €

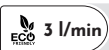

07362.220.EN
253,00 €

07362.EN
302,50 €

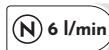

07362.220.N
247,50 €

07362.N
297,00 €



07362M.220.LB

Laserlux

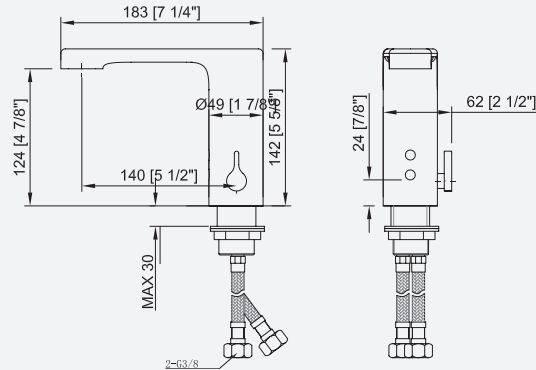

1,89 l/min

07362M.220.LB
260,00 €

07362M.LB
305,00 €



3 l/min

07362M.220.EB
265,00 €

07362M.EB
310,00 €



6 l/min

07362M.220.B
260,00 €

07362M.B
305,00 €

○ Grifo electrónico mezclador para lavabo encimera. Activación por sensor láser. Alimentación por baterías o corriente eléctrica

● Misturador eletrônico para lavatório de bancada. Ativação por sensor laser. Alimentado por baterias ou corrente elétrica

● Rubinetto elettronico miscelatore per bordo lavabo. Attivazione per sensore laser. Alimentato da batterie o corrente elettrica

⊙ Mitigeur électronique de lavabo installation sur plan de travail. Déclenchement par capteur laser. Alimenté par batteries ou du courant électrique



07362M.220.LN

Laserlux

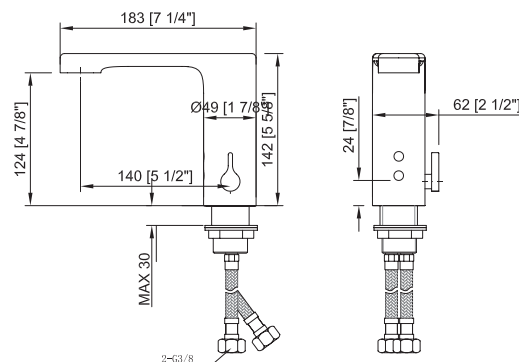

1,89 l/min

07362M.220.LN
286,00 €

07362M.LN
335,50 €



3 l/min

07362M.220.EN
291,50 €

07362M.EN
341,00 €

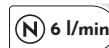

6 l/min

07362M.220.N
286,00 €

07362M.N
335,50 €



○ Grifería electrónica

● Torneria eletrônica

● Rubinetteria elettronica

◎ Robinet électronique



07360.220.LB

Evomatic

○ Grifo electrónico para lavabo encimera. Activación por sensor láser. Alimentación mediante batería recargable o corriente eléctrica. Alimentación solo por corriente eléctrica 07360.220.B, 07360.220.EB y 07360.220.LB

● Torneira eletrônica para lavatório de bancada. Ativação por sensor laser. Alimentado da batterie ricaricabili o corrente elettrica. Alimentado somente por corrente elétrica 07360.220.B, 07360.220.EB e 07360.220.LB

● Rubinetto elettronico per bordo lavabo. Attivazione per sensore laser. Alimentato da batterie ricaricabili o da corrente elettrica. Alimentazione solo da corrente elettrica 07360.220.B, 07360.220.EB e 07360.220.LB

◎ Robinet électronique de lavabo installation sur plan de travail. Déclenchement par capteur laser. Alimenté par batteries rechargeables ou du courant électrique. Alimentation uniquement par courant électrique 07360.220.B, 07360.220.EB et 07360.220.LB

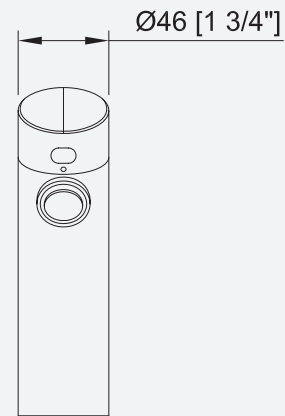
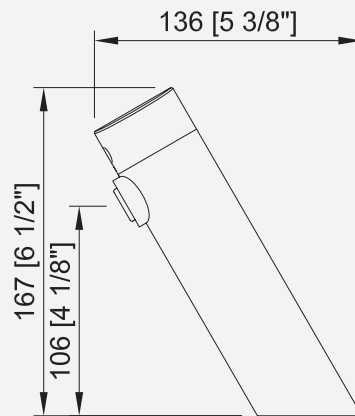

07360.220.LB
232,00 €



07360.220.EB
237,50 €



07360.220.B
232,00 €

07360.LB
283,50 €

07360.EB
289,00 €

07360.B
283,50 €



07360M.220.LB

Evomatic

○ Grifo mezclador electrónico sobre encimera. Activación por sensor láser. Alimentación mediante batería recargable o corriente eléctrica. Alimentación solo por corriente eléctrica 07360M.220.B, 07360M.220.EB y 07360M.220.LB

● Misturador eletrônico em bancada. Ativação por sensor laser. Alimentado por baterias recarregáveis ou corrente elétrica. Alimentado somente por corrente elétrica 07360M.220.B, 07360M.220.EB e 07360M.220.LB

● Miscelatore elettronico per bordo lavabo. Attivazione per sensore laser. Alimentato da batterie ricaricabili o corrente elettrica. Alimentazione solo da corrente elettrica 07360M.220.B, 07360M.220.EB e 07360M.220.LB

◎ Mitigeur électronique installation sur plan de travail. Déclenchement par capteur laser. Alimenté par batteries rechargeables ou du courant électrique. Alimentation uniquement par courant électrique 07360M.220.B, 07360M.220.EB et 07360M.220.LB

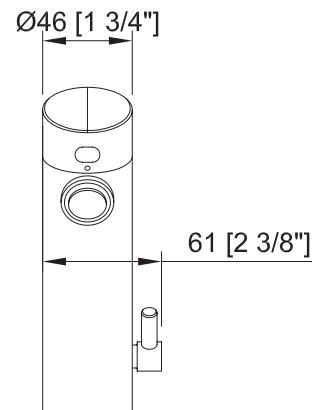
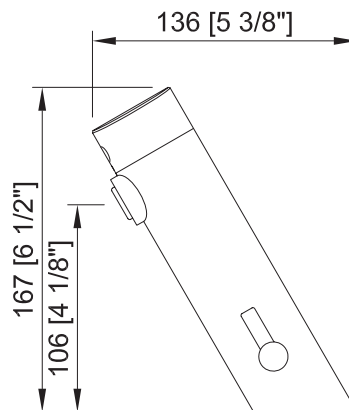

07360M.220.LB
270,00 €



07360M.220.EB
275,50 €

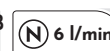

07360M.220.B
270,00 €

07360M.LB
315,00 €

07360M.EB
319,00 €

07360M.B
315,00 €



07361.220.LB

Evomatic

○ Grifo electrónico mural. Activación por sensor láser. Alimentación mediante batería recargable o corriente eléctrica. Alimentación solo por corriente eléctrica 07361.220.B, 07361.220.EB y 07361.220.LB

● Torneira eletrônica mural. Ativação por sensor laser. Alimentado por baterias recarregáveis ou corrente elétrica. Alimentado somente por corrente elétrica 07361.220.B, 07361.220.EB e 07361.220.LB

● Rubinetto elettronico a parete. Attivazione per sensore laser. Alimentato da batterie ricaricabili o corrente elettrica. Alimentazione solo da corrente elettrica 07361.220.B, 07361.220.EB e 07361.220.LB

◎ Robinet électronique mural. Déclenchement par capteur laser. Alimenté par batteries rechargeables ou du courant électrique. Alimentation uniquement par courant électrique 07361.220.B, 07361.220.EB et 07361.220.LB

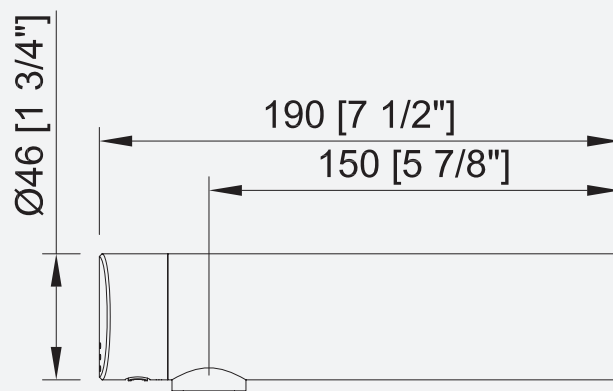

1,89 l/min	07361.220.LB 260,00 €	3 l/min	07361.220.EB 265,50 €	6 l/min	07361.220.B 260,00 €
	07361.LB 305,00 €		07361.EB 310,00 €		07361.B 305,00 €



07361M.220.LB

Evomatic

○ Grifo mezclador electrónico mural. Activación por sensor láser. Alimentación mediante batería recargable o corriente eléctrica. Alimentación solo por corriente eléctrica 07361M.220.B, 07361M.220.EB y 07361M.220.LB

● Misturador eletrônica mural. Ativação por sensor laser. Alimentado por baterias recarregáveis ou corrente elétrica. Alimentado somente por corrente elétrica 07361M.220.B, 07361M.220.EB e 07361M.220.LB

● Miscelatore elettronico a parete. Attivazione per sensore laser. Alimentato da batterie ricaricabili o corrente elettrica. Alimentazione solo da corrente elettrica 07361M.220.B, 07361M.220.EB e 07361M.220.LB

◎ Mitigeur électronique mural. Déclenchement par capteur laser. Alimenté par batteries rechargeables ou du courant électrique. Alimentation uniquement par courant électrique 07361M.220.B, 07361M.220.EB et 07361M.220.LB

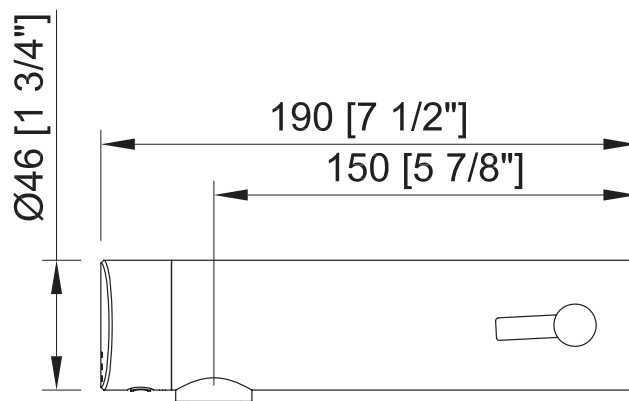
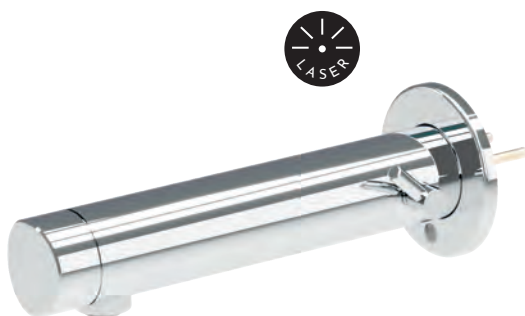

1,89 l/min	07361M.220.LB 303,00 €	3 l/min	07361M.220.EB 308,00 €	6 l/min	07361M.220.B 303,00 €
	07361M.LB 346,00 €		07361M.EB 351,00 €		07361M.B 346,00 €



BRILLO



SATINADO



DORADO

Tecnología de color PVD en cada gota

Innovación en cada gota: Descubre la tecnología de pintado en colores PVD de NOFER

Colores Vibrantes y Duraderos: Gama amplia gracias a la tecnología PVD para resistir decoloración.

Estilo Vanguardista: Diseño moderno que transforma espacios con elegancia.

Tecnología PVD Avanzada: Capa resistente y duradera que conserva el brillo original, incluso ante el desgaste diario.



Grifería electrónica

Torneria eletrônica

Rubinetteria elettronica

Robinet électronique

Dosificador jabón láser

Cuerpo de latón CW617N cromado bajo la norma EN 248

Activación mediante sensor laser

Dosificación 1 ml regulable. Depósito 1500 ml

Alimentación mediante batería recargable o corriente eléctrica

Doseador de sabão a laser

Corpo de latão CW617N, cromado baixo a norma EN 248

Ativação por sensor laser

Dosagem 1 ml ajustável. Depósito 1500 ml

Alimentado por baterias ou corrente elétrica

Distributore di sapone laser

Corpo in ottone CW617N cromato secondo la normativa EN 248

Attivazione sensore laser

Dosaggio regolabile 1 ml. Serbatoio 1500 ml

Alimentato da batterie o corrente elettrica

Distributeur de savon laser

Corps en laiton CW617N, chromé selon la norme EN 248

Déclenchement par capteur laser

Dosage réglable 1 ml. Réservoir 1500 ml

Alimenté par batteries ou du courant électrique



03312.220.B

Evomatic

○ Dosificador de jabón sobre encimera. Activación por sensor láser. Alimentación mediante batería recargable o corriente eléctrica. Alimentación solo por corriente eléctrica 03312.220.B

● Dosificador de sabonete en bancada. Ativação por sensor laser. Alimentado por baterias recarregáveis ou corrente elétrica. Alimentado somente por corrente elétrica 03312.220.B

● Dosatore di sapone bordo lavabo. Attivazione per sensore laser. Alimentato da batterie ricaricabili o corrente elettrica. Alimentazione solo da corrente elettrica 03312.220.B

◎ Distributeur de savon installation sur plan de travail. Déclenchement par capteur laser. Alimenté par batteries rechargeables ou du courant électrique. Alimentation uniquement par courant électrique 03312.220.B

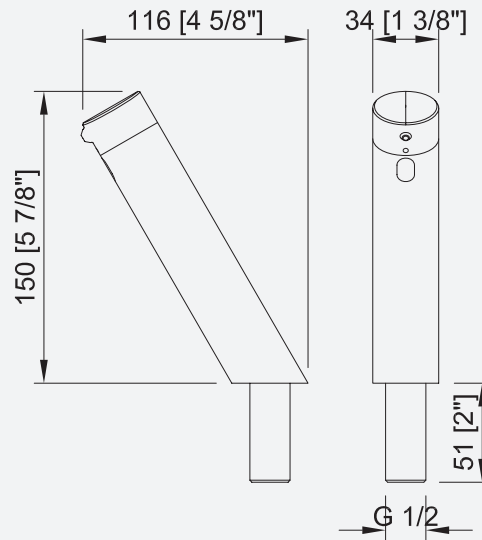

03312.220.B
278,00 €

03312.B
321,00 €

03313.220.B

Evomatic

○ Dosificador de jabón mural. Activación por sensor láser. Alimentación mediante batería recargable o corriente eléctrica. Alimentación solo por corriente eléctrica 03313.220.B

● Dosificador de sabonete mural. Ativação por sensor laser. Alimentado da batterie ricaricabili o corrente elettrica. Alimentado somente por corrente elétrica 03313.220.B

● Dosatore di sapone a parete. Attivazione per sensore laser. Alimentato da batterie ricaricabili o da corrente elettrica. Alimentazione solo da corrente elettrica 03313.220.B

◎ Robinet de lavabo mural temporisé, installation visible. Alimenté par batteries rechargeables ou du courant électrique. Alimentation uniquement par courant électrique 03313.220.B

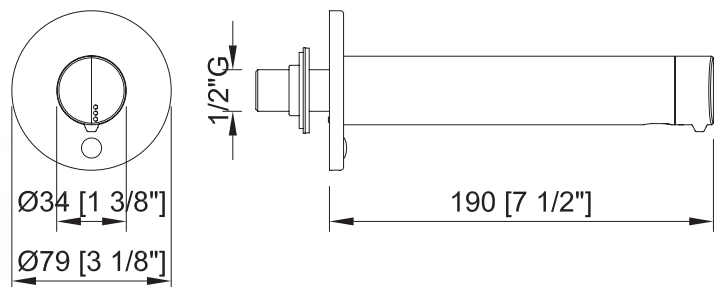
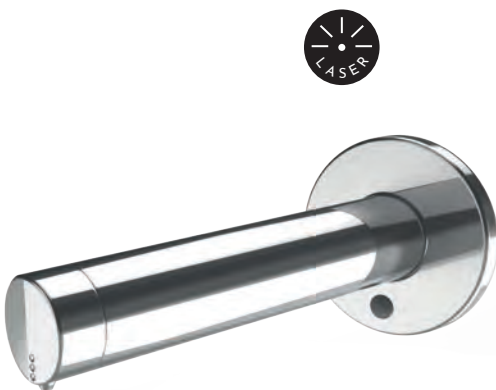

03313.220.B
294,50 €

03313.B
338,00 €

○ GRIFERÍA
SOBRE ENCIMERA

● TORNEIRAS DE
BANCADA

● RUBINETTI BORDO
LAVABO

◎ ROBINETS SUR
PLAN DE TRAVAIL





Encimera

Adecuado para zonas de alta frecuencia de uso y requisitos higiénicos elevados

Activación mediante sensor de infrarrojos

Alimentación mediante corriente eléctrica o baterías

Cuerpo de latón CW617N cromado bajo la norma EN 248. Componentes plásticos en POM

Temperatura de trabajo 1-80° C. Temperatura máxima recomendada 60° C

Presión de trabajo entre 0,5-6 bar. Presión recomendada 3 bar

Aireador plástico anti cal y filtro antipartículas

Disponibles versiones estándar 6 l/min, ECO 3 l/min y LEED 1,89 l/min



Bancada

Adecuado para áreas de uso de alta frequência e altos requisitos de higiene

Ativação por sensor infravermelho

Fonte de alimentação por corrente elétrica ou baterias

Corpo de latão CW617N, cromado de acordo com a norma EN 248. Componentes de plástico POM

Temperatura de trabalho 1-80° C. Temperatura máxima recomendada 60° C

Pressão de trabalho entre 0,5-6 bar. Pressão recomendada 3 bar

Aerador de plástico anti-calcário e filtro anti-partículas

Versões standard disponíveis 6 l/min, ECO 3 l/min e LEED 1,89 l/min



Rubinetti bordo lavabo

Adatto per aree ad alta frequenza di utilizzo ed elevati requisiti igienici

Attivazione tramite sensore a infrarossi

Alimentato da corrente elettrica o da batterie

Corpo in ottone cromato CW617N secondo normativa EN 248. Componenti in plastica in POM

Temperatura di esercizio 1-80° C. Temperaturamassima consigliata 60° C

Pressione di esercizio tra 0,5-6 bar. Pressione consigliata 3 bar

Aeratore anticalcare in plastica e filtro antiparticolato

Versioni standard disponibili 6 l/min, ECO 3 l/min e LEED 1,89 l/min



Plan de travail

Approprié aux zones d'utilisation à haute fréquence et aux exigences d'hygiène élevées

Déclenchement par capteur infrarouge

Alimentation électrique ou à piles

Corps en laiton CW617N, chromé selon la norme EN 248. Composants plastiques en POM

Température de fonctionnement 1-80° C. Température maximale recommandée 60° C

Pression de fonctionnement entre 0,5-6 bar. Pression recommandée 3 bars

Aérateur en plastique antical-caire et filtre antiparticules

Disponibles en versions standard 6 l/min, ECO 3 l/min et LEED 1,89 l/min

07250.B

Luxmatic

○ Grifo electrónico un agua para lavabo encimera. Alimentación por baterías o corriente eléctrica

● Rubinetto elettronico per lavabo sopra piano. Alimentato da batterie ricaricabili o corrente elettrica

● Torneira eletrônica para lavatório bancada. Alimentado por baterias ou corrente elétrica

⊙ Robinet électronique à une eau pour lavemains sur plan de travail. Alimenté par batteries ou du courant électrique

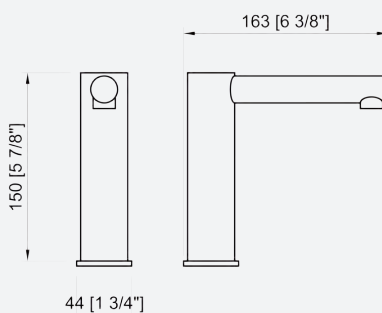

07250.B
450,00 €



○ Grifería electrónica

● Torneria eletrônica

● Rubinetteria elettronica

⊙ Robinet électronique



07261.LB Essentialmatic

○ Grifo electrónico un agua para lavabo encimera. Alimentación por baterías o corriente eléctrica

● Torneira eletrônica para lavatório bancada. Alimentado por baterias ou corrente elétrica

● Rubinetto elettronico per bordo lavabo. Alimentato da batterie o corrente elettrica

⊙ Robinet électronique à une eau pour lavemains sur plan de travail. Alimenté par batteries ou du courant électrique

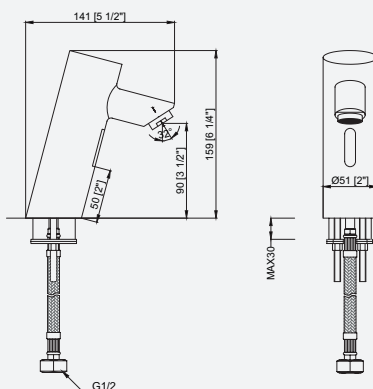

1,89 l/min	07261.LB 186,00 €
3 l/min	07261.EB 190,00 €
6 l/min	07261.B 185,00 €



07261.LN Essentialmatic

○ Grifo electrónico un agua para lavabo encimera. Alimentación por baterías o corriente eléctrica

● Torneira eletrônica para lavatório bancada. Alimentado por baterias ou corrente elétrica

● Rubinetto elettronico per bordo lavabo. Alimentato da batterie o corrente elettrica

⊙ Robinet électronique à une eau pour lavemains sur plan de travail. Alimenté par batteries ou du courant électrique

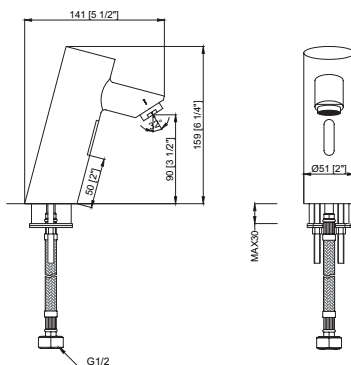

1,89 l/min	07261.LN 204,50 €
3 l/min	07261.EN 208,50 €
6 l/min	07261.N 203,50 €



07260.LB Luxmatic

○ Grifo electrónico un agua para lavabo encimera. Alimentación por baterías o corriente eléctrica

● Torneira eletrônica para lavatório bancada. Alimentado por baterias ou corrente elétrica

● Rubinetto elettronico per bordo lavabo. Alimentato da batterie o corrente elettrica

⊙ Robinet électronique à une eau pour lavemains sur plan de travail. Alimenté par batteries ou du courant électrique

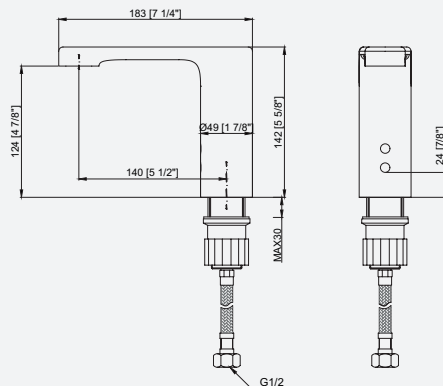

1,89 l/min	07260.LB 228,00 €
3 l/min	07260.EB 232,00 €
6 l/min	07260.B 227,00 €



07260.LN

Luxmatic



○ Grifo electrónico un agua para lavabo encimera. Alimentación por baterías o corriente eléctrica

● Rubinetto elettronico per lavabo sopra piano. Alimentato da batterie ricaricabili o corrente elettrica

● Torneira eletrônica para lavatório bancada. Alimentado por baterias ou corrente elétrica

⊙ Robinet électronique à une eau pour lavemains sur plan de travail. Alimenté par batteries ou du courant électrique

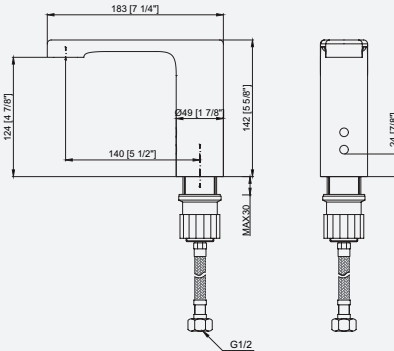

1,89 l/min **07260.LN**
251,00 €

3 l/min **07260.EN**
255,00 €

6 l/min **07260.N**
250,00 €



07264.LB

Luxmatic



○ Grifo alto electrónico un agua para lavabo encimera. Alimentación por baterías o corriente eléctrica

● Rubinetto alto elettronico per lavabo sopra piano. Alimentato da batterie ricaricabili o corrente elettrica

● Torneira alta eletrônica para lavatório bancada. Alimentação por baterias ou corrente elétrica

⊙ Robinet haut électronique à une eau pour lavemains sur plan de travail. Alimenté par batteries ou du courant électrique

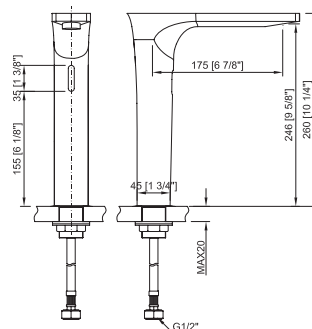

1,89 l/min **07264.LB**
275,00 €

3 l/min **07264.EB**
280,00 €

6 l/min **07264.B**
275,00 €



07261M.LB

Essentialmatic



○ Grifo electrónico mezclador para lavabo encimera. Alimentación por baterías o corriente eléctrica

● Rubinetto miscelatore elettronico per lavabo sopra piano. Alimentato da batterie ricaricabili o corrente elettrica

● Torneira eletrônica misturadora para lavatório. Alimentação por baterias ou corrente elétrica

⊙ Mitigeur électronique pour lavemains sur plan de travail. Alimenté par batteries ou du courant électrique

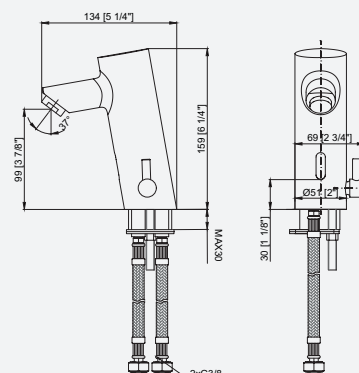

1,89 l/min **07261M.LB**
234,50 €

3 l/min **07261M.EB**
238,50 €

6 l/min **07261M.B**
233,50 €



○ Grifería electrónica

● Torneria eletrônica

● Rubinetteria elettronica

● Robinet électronique



07261M.LN Essentialmatic



- Grifo electrónico mezclador para lavabo encimera. Alimentación por baterías o corriente eléctrica
- Rubinetto miscelatore elettronico per lavabo sopra piano. Alimentato da batterie o corrente elettrica

- Torneira eletrônica misturadora para lavatório. Alimentado por baterias ou corrente elétrica
- Robinet électronique à une eau pour lavemains sur plan de travail. Alimenté par batteries ou du courant électrique

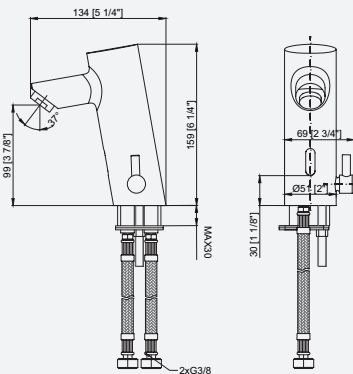

	1,89 l/min	07261M.LN 257,50 €
	3 l/min	07261M.EN 261,50 €
	6 l/min	07261M.N 256,50 €



07260M.LB Luxmatic



- Grifo electrónico mezclador para lavabo encimera. Alimentación por baterías o corriente eléctrica
- Rubinetto miscelatore elettronico per lavabo sopra piano. Alimentato da batterie o corrente elettrica

- Torneira eletrônica misturadora para lavatório. Alimentado por baterias ou corrente elétrica
- Robinet électronique à une eau pour lavemains sur plan de travail. Alimenté par batteries ou du courant électrique

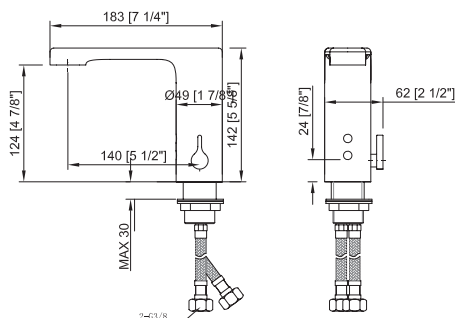

	1,89 l/min	07260M.LB 262,00 €
	3 l/min	07260M.EB 267,00 €
	6 l/min	07260M.B 262,00 €



07260M.LN Luxmatic



- Grifo electrónico mezclador para lavabo encimera. Alimentación por baterías o corriente eléctrica
- Rubinetto miscelatore elettronico per lavabo sopra piano. Alimentato da batterie o corrente elettrica

- Torneira eletrônica misturadora para lavatório. Alimentado por baterias ou corrente elétrica
- Robinet électronique à une eau pour lavemains sur plan de travail. Alimenté par batteries ou du courant électrique

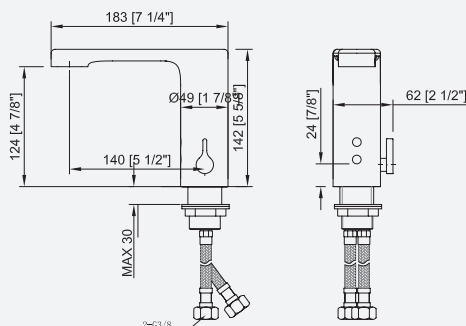

	1,89 l/min	07260M.LN 289,00 €
	3 l/min	07260M.EN 293,00 €
	6 l/min	07260M.N 288,00 €



○ GRIFERÍA MURAL

● TORNEIRAS MURAIIS

● RUBINETTI A
PARETE

◎ ROBINETS MURAUX





Mural

Adecuado para zonas de alta frecuencia de uso y requisitos higiénicos elevados

Activación mediante sensor de infrarrojos

Operación mediante 4 baterías AAA. Grifo 07265.B también conexión a red eléctrica

Cuerpo de latón CW617N cromado bajo la norma EN 248. Componentes plásticos en POM

Temperatura de trabajo 1-80° C. Temperatura máxima recomendada 60° C

Presión de trabajo entre 0,5-6 bar. Presión recomendada 3 bar

Aireador plástico anti cal y filtro antipartículas

Disponibles versiones estándar 6 l/min, ECO 3 l/min y LEED 1,89 l/min



Mural

Adecuado para áreas de uso de alta frequência e altos requisitos de higiene

Ativação por sensor infravermelho

Operación mediante 4 baterías AAA. Torneira 07265.B também conexão à rede elétrica

Corpo de latão CW617N, cromado de acordo com a norma EN 248. Componentes de plástico POM

Temperatura de trabalho 1-80° C. Temperatura máxima recomendada 60° C

Pressão de trabalho entre 0,5-6 bar. Pressão recomendada 3 bar

Aerador de plástico anti-calcário e filtro anti-partículas

Versões standard disponíveis 6 l/min, ECO 3 l/min e LEED 1,89 l/min



A parete

Adatto per aree ad alta frequenza di utilizzo ed elevati requisiti igienici

Attivazione tramite sensore a infrarossi

Funzionamento tramite 4 batterie AAA. Rubinetto 07265.B anche collegamento alla rete elettrica

Corpo in ottone cromato CW617N secondo normativa EN 248. Componenti in plastica in POM

Temperatura di esercizio 1-80° C. Temperaturamassima consigliata 60° C

Pressione di esercizio tra 0,5-6 bar. Pressione consigliata 3 bar

Aeratore anticalcare in plastica e filtro antiparticolato

Versioni standard disponibili 6 l/min, ECO 3 l/min e LEED 1,89 l/min



Mural

Approprié aux zones d'utilisation à haute fréquence et aux exigences d'hygiène élevées

Déclenchement par capteur infrarouge

Operación mediante 4 baterías AAA. Robinet 07265.B également raccordement au réseau électrique

Corps en laiton CW617N, chromé selon la norme EN 248. Composants plastiques en POM

Température de fonctionnement 1-80° C. Température maximale recommandée 60° C

Pression de fonctionnement entre 0,5-6 bar. Pression recommandée 3 bars

Aérateur en plastique anticalcaire et filtre antiparticules

Disponibles en versions standard 6 l/min, ECO 3 l/min et LEED 1,89 l/min



○ Grifería electrónica

● Torneria eletrônica

● Rubinetteria elettronica

⊙ Robinet électronique



07263.LB Essentialmatic

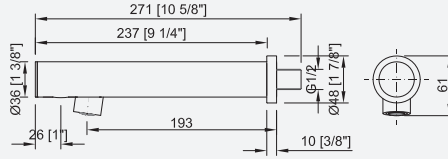

1,89 l/min **07263.LB**
209,50 €

3 l/min **07263.EB**
213,50 €

6 l/min **07263.B**
208,50 €

- Grifo electrónico mural un agua para lavabo. Alimentación mediante baterías
- Rubinetto elettronico a parete monocomando per lavabo. Alimentato da batterie

- Torneira mural eletrônica uma água para lavatório. Alimentado por baterias
- ⊙ Robinet de lavabo électronique mural à une eau. Alimenté par batteries



07263.LN Essentialmatic

NEW • NUEVO • NOUVEAU

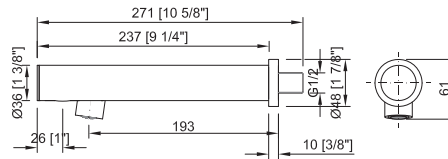

1,89 l/min **07263.LN**
231,00 €

3 l/min **07263.EN**
235,00 €

6 l/min **07263.N**
230,00 €

- Grifo electrónico mural un agua para lavabo. Alimentación mediante baterías
- Rubinetto elettronico a parete monocomando per lavabo. Alimentato da batterie

- Torneira mural eletrônica uma água para lavatório. Alimentado por baterias
- ⊙ Robinet de lavabo électronique mural à une eau. Alimenté par batteries



07265.LB Luxmatic

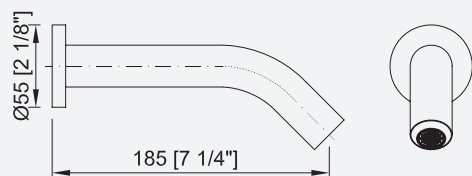

1,89 l/min **07265.LB**
221,00 €

3 l/min **07265.EB**
225,00 €

6 l/min **07265.B**
220,00 €

- Grifo electrónico mural un agua para lavabo. Alimentación por baterías o corriente eléctrica
- Rubinetto elettronico a parete monocomando per lavabo. Alimentato da batterie o corrente elettrica

- Torneira mural eletrônica uma água para lavatório. Alimentado por baterias ou corrente elétrica
- ⊙ Robinet de lavabo électronique mural à une eau. Alimenté par batteries ou du courant électrique



07263M.LB

Essentialmatic

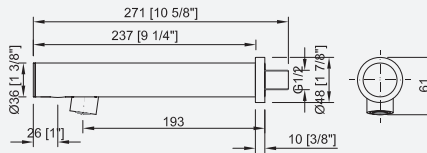

- Grifo electrónico mural un agua para lavabo. Alimentación mediante baterías
- Miscelatore elettronico a parete monocomando per lavabo. Alimentato da batterie

- Torneira misturadora mural eletrônica para lavatório. Alimentado por baterias
- ⊙ Mitigeur électronique mural de lavabo à une eau. Alimenté par batteries

1,89 l/min	07263M.LB 266,00 €
3 l/min	07263M.EB 288,50 €
6 l/min	07263M.B 265,00 €



07263M.LN

Essentialmatic

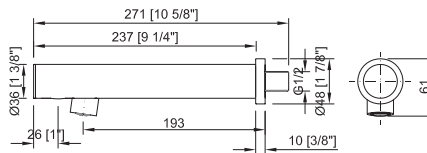

- Grifo electrónico mural un agua para lavabo. Alimentación mediante baterías
- Miscelatore elettronico a parete monocomando per lavabo. Alimentato da batterie

- Torneira misturadora mural eletrônica para lavatório. Alimentado por baterias
- ⊙ Mitigeur électronique mural de lavabo à une eau. Alimenté par batteries

1,89 l/min	07263M.LN 287,50 €
3 l/min	07263M.EN 316,50 €
6 l/min	07263M.N 286,50 €



○ Grifería electrónica

● Torneria eletrônica

● Rubinetteria elettronica

⦿ Robinet électronique

○
Fregadero

Adecuado para zonas de alta frecuencia de uso y requisitos higiénicos elevados

Activación mediante sensor de infrarrojos

Operación mediante conexión a red eléctrica utilizando 4 baterías AA como back up de seguridad

Cuerpo de latón CW617N cromado bajo la norma EN 248. Componentes plásticos en POM

Temperatura de trabajo 1-80° C. Temperatura máxima recomendada 60° C

Presión de trabajo entre 0,5-6 bar. Presión recomendada 3 bar

Aireador plástico anti cal y filtro antipartículas

Disponibles versiones estándar 6 l/min, ECO 3 l/min y LEED 1,89 l/min

●
Fregadero

Adecuado para áreas de uso de alta frequência e altos requisitos de higiene

Ativação por sensor infravermelho

Operação por conexão à rede elétrica usando 4 baterias AA como um backup de segurança

Corpo de latão CW617N, cromado de acordo com a norma EN 248. Componentes de plástico POM

Temperatura de trabalho 1-80° C. Temperatura máxima recomendada 60° C

Pressão de trabalho entre 0,5-6 bar. Pressão recomendada 3 bar

Aerador de plástico anti-calcário e filtro anti-partículas

Versões standard disponíveis 6 l/min, ECO 3 l/min e LEED 1,89 l/min

●
Lavello

Adatto per aree ad alta frequenza di utilizzo ed elevati requisiti igienici

Attivazione tramite sensore a infrarossi

Funzionamento tramite collegamento alla rete elettrica utilizzando 4 batterie AA come backup di sicurezza

Corpo in ottone cromato CW617N secondo normativa EN 248. Componenti in plastica in POM

Temperatura di esercizio 1-80° C. Temperaturamassima consigliata 60° C

Pressione di esercizio tra 0,5-6 bar. Pressione consigliata 3 bar

Aeratore anticalcare in plastica e filtro antiparticolato

Versioni standard disponibili 6 l/min, ECO 3 l/min e LEED 1,89 l/min

⦿
Évier

Approprié aux zones d'utilisation à haute fréquence et aux exigences d'hygiène élevées

Déclenchement par capteur infrarouge

Fonctionnement par connexion au réseau électrique en utilisant 4 piles AA comme sauvegarde de sécurité

Corps en laiton CW617N, chromé selon la norme EN 248. Composants plastiques en POM

Température de fonctionnement 1-80° C. Température maximale recommandée 60° C

Pression de fonctionnement entre 0,5-6 bar. Pression recommandée 3 bars

Aérateur en plastique antical-caire et filtre antiparticules

Disponibles en versions standard 6 l/min, ECO 3 l/min et LEED 1,89 l/min



07262.B 07262.N

Essentialmatic



- Grifo electrónico un agua para fregadero. Alimentado por baterías o corriente eléctrica
- Torneira eletrônica uma água para pia. Alimentado por baterías ou corrente eléctrica
- Rubinetto elettronico monocomando per lavello. Alimentato da batterie o corrente elettrica
- ⊙ Robinet électronique d'évier à une eau. Alimenté par batteries ou du courant électrique

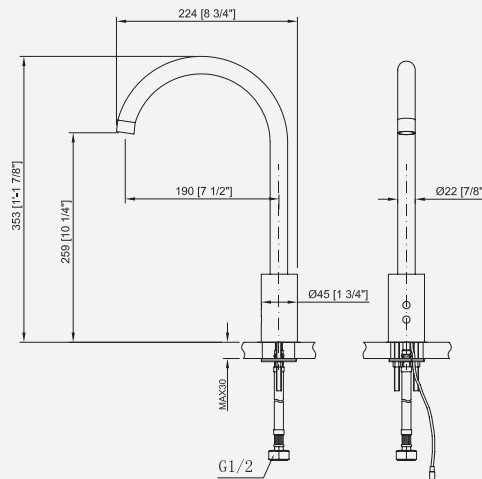

N 6 l/min **07262.B**
220,00 €

N 6 l/min **07262.N**
242,00 €

07262M.B

Essentialmatic



- Grifo electrónico mezclador para fregadero. Alimentado por baterías o corriente eléctrica
- Torneira misturadora eletrônica uma água para pia. Alimentado por baterías ou corrente eléctrica
- Miscelatore elettronico per lavello. Alimentato da batterie ricaricabili o corrente elettrica
- ⊙ Mitigeur électronique d'évier. Alimenté par batteries ou du courant électrique

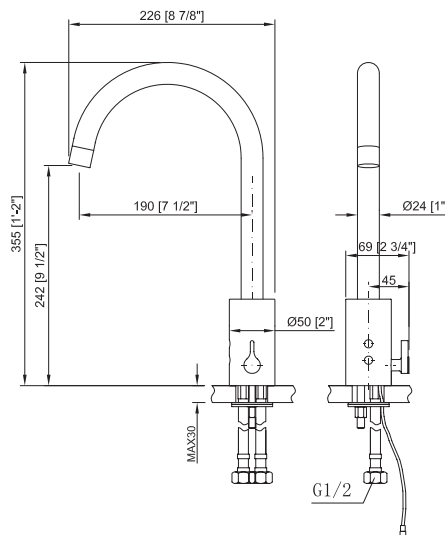

N 6 l/min **07262M.B**
250,00 €



○ Grifería electrónica

● Torneria eletrônica

● Rubinetteria elettronica

⊙ Robinet électronique

○ **Dosificador jabón electrónico**

Adecuado para zonas de alta frecuencia de uso y requisitos higiénicos elevados

Activación mediante sensor de infrarrojos

Alimentación mediante corriente eléctrica

Cuerpo de latón CW617N cromado bajo la norma EN 248. Componentes plásticos en POM

Dosificación 1 ml regulable Depósito 1000 ml

● **Distribuidor eletrônico de sabonete**

Adecuado para áreas de uso de alta frequência e altos requisitos de higiene

Ativação por sensor infravermelho

Fonte de alimentação por corrente elétrica

Corpo de latão CW617N, cromado de acordo com a norma EN 248. Componentes de plástico POM

Dosagem 1 ml ajustável Depósito 1000 ml

● **Dosatore di sapone elettrico**

Adatto per aree ad alta frequenza di utilizzo ed elevati requisiti igienici

Attivazione tramite sensore a infrarossi

Alimentato da corrente elettrica

Corpo in ottone cromato CW617N secondo normativa EN 248. Componenti in plastica in POM

Dosaggio regolabile 1 ml Serbatoio 1000 ml

⊙ **Distributeur de savon électronique**

Approprié aux zones d'utilisation à haute fréquence et aux exigences d'hygiène élevées

Déclenchement par capteur infrarouge

Alimentation électrique

Corps en laiton CW617N, chromé selon la norme EN 248. Composants plastiques en POM

Dosage réglable 1 ml Réservoir 1000 ml

03120.B
03120.N

Essentialmatic



○ Dosificador electrónico de jabón mural. Alimentado por corriente eléctrica

● Dosificador eletrônico de sabonete mural. Alimentado por corrente elétrica

● Dosatore elettrico di sapone a parete. Alimentato da corrente elettrica

⊙ Distributeur de savon électronique mural. Alimenté par courant électrique

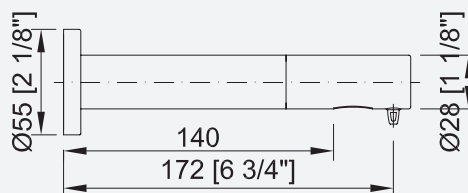

03120.B
205,00 €

03120.N
225,00 €



03121.B

Luxmatic



○ Dosificador electrónico de jabón mural. Alimentado por corriente eléctrica

● Dosificador eletrônico de sabonete mural. Alimentado por corrente elétrica

● Dosatore elettrico di sapone a parete. Alimentato da corrente elettrica

⊙ Distributeur de savon électronique mural. Alimenté par courant électrique

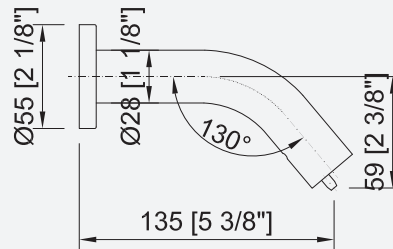

03121.B
165,00 €

03114.B

Luxmatic



○ Dosificador electrónico de jabón sobre encimera. Alimentado por corriente eléctrica

● Dosificador eletrônico de sabonete em bancada. Alimentado por corrente elétrica

● Dosatore elettronico di sapone bordo lavabo. Alimentato da corrente elettrica

⊙ Distributeur de savon électronique à installation sur plan de travail. Alimenté par courant électrique

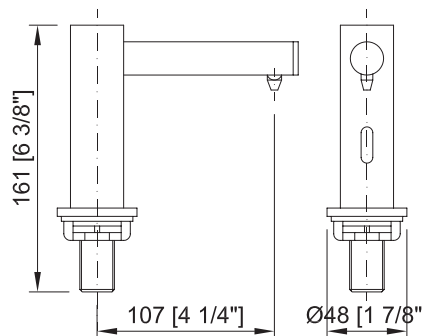

03114.B
205,00 €

03113.B 03113.N

Essentialmatic



○ Dosificador electrónico de jabón sobre encimera. Alimentado por corriente eléctrica

● Dosificador eletrônico de sabonete em bancada. Alimentado por corrente elétrica

● Dosatore elettrico di sapone bordo lavabo. Alimentato da corrente elettrica

⊙ Distributeur de savon électronique à installation sur plan de travail. Alimenté par courant électrique

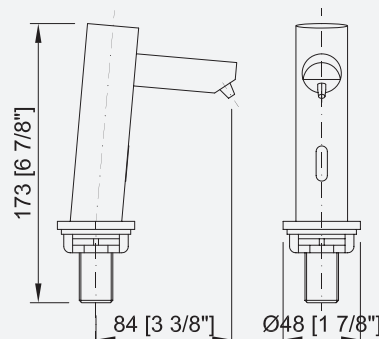

03113.B
205,00 €

03113.N
225,00 €

○ GRIFERÍA PARA
URINARIO

● RUBINETTI PER
ORINATOIO

● TORNEIRAS PARA
URINOL

◎ RUBINETS POUR
URINOIR



○
**Grifería
para
urinario**

Adecuado para zonas de alta frecuencia de uso y requisitos higiénicos elevados

Activación mediante sensor de infrarrojos

Operación mediante conexión a red eléctrica utilizando 4 baterías AAA como back up de seguridad

Embellecedor de aluminio inyectado cromado bajo la norma EN248. Cuerpo de latón CW617N cromado bajo la norma EN248. Componentes plásticos en POM

Alimentación mediante baterías

Tiempo de actuación 4 s

Presión de trabajo entre 0,5-6 bar. Presión recomendada 3 bar

Filtro antipartículas

Precisa enlace de conexión no incluido

●
**Torneira
para
urinol**

Adecuado para áreas de uso de alta frecuencia e altos requisitos de higiene

Ativação por sensor infravermelho

Operação conectando 4 baterias AAA como um backup de segurança

Guarnição em alumínio injetado cromado segundo a norma EN248. Corpo em latão cromado CW617N de acordo com a norma EN248. Componentes plásticos em POM

Alimentado por bateria

Tempo de atuação 4 s

Pressão de trabalho entre 0,5-6 bar. Pressão recomendada 3 bar

Filtro anti-particulado

Link de conexão precisa não incluído

●
**Rubinetteria
per orinatoio**

Adatto per aree ad alta frequenza di utilizzo ed elevati requisiti igienici

Attivazione tramite sensore a infrarossi

Funzionamento tramite collegamento 4 batterie AAA come backup di sicurezza

Lunetta di abbellimento in alluminio pressofuso cromato secondo la norma EN248. Struttura d'ottone CW617N cromato secondo la norma EN248. Parti in plastica POM

Alimentazione a batteria

Tempo di prestazione 4 s

Pressione di esercizio tra 0,5-6 bar. Pressione consigliata 3 bar

Filtro antiparticolato

Collegamento di connessione richiesto non incluso

⦿
**Robinet
électronique
pour urinoir**

Approprié aux zones d'utilisation à haute fréquence et aux exigences d'hygiène élevées

Déclenchement par capteur infrarouge

Operación mediante 4 baterías AAA. Robinet 07265.B également raccordement au réseau électrique

Cache en aluminium injecté chromé, conforme à la norme EN248. Corps en laiton CW617N, chromé selon la norme EN248. Composants plastiques en POM

Alimentation à piles

Durée de fonctionnement 4 s

Pression de fonctionnement entre 0,5-6 bar. Pression recommandée 3 bars

Filtre antiparticules

Il est nécessaire un raccord de connexion non inclus



○ Grifería electrónica

● Torneria eletrônica

● Rubinetteria elettronica

⊙ Robinet électronique

07280.B

Essentialmatic

○ Grifo electrónico para urinario. Instalación empotrada. Alimentación por baterías o corriente eléctrica

● Torneira eletrônica para urinál. Instalação embutida. Alimentado por baterias ou corrente elétrica

● Rubinetto elettronico monocomando per bordo lavabo. Installazione ad incasso. Alimentato da batterie o corrente elettrica

⊙ Robinet électronique pour urinaire. Installation encastrée. Alimenté par batteries ou du courant électrique

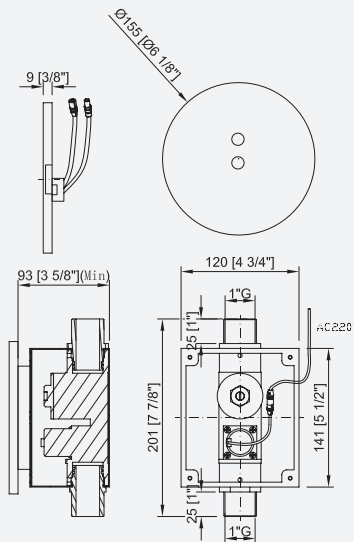

07280.B
205,00 €

07280.LB
206,00 €

07281.B

Essentialmatic

○ Grifo electrónico mural para urinario. Instalación vista. Alimentación por baterías

● Torneira eletrônica mural para urinál. Instalação vista. Alimentado por baterias

● Rubinetto elettronico a parete per orinatoio. Installazione a vista. Alimentato da batterie

⊙ Robinet électronique mural pour urinoir. Installation visible. Alimenté par batteries

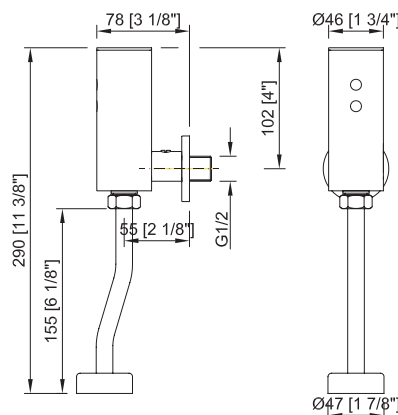

07281.B
190,00 €

07281.LB
191,00 €

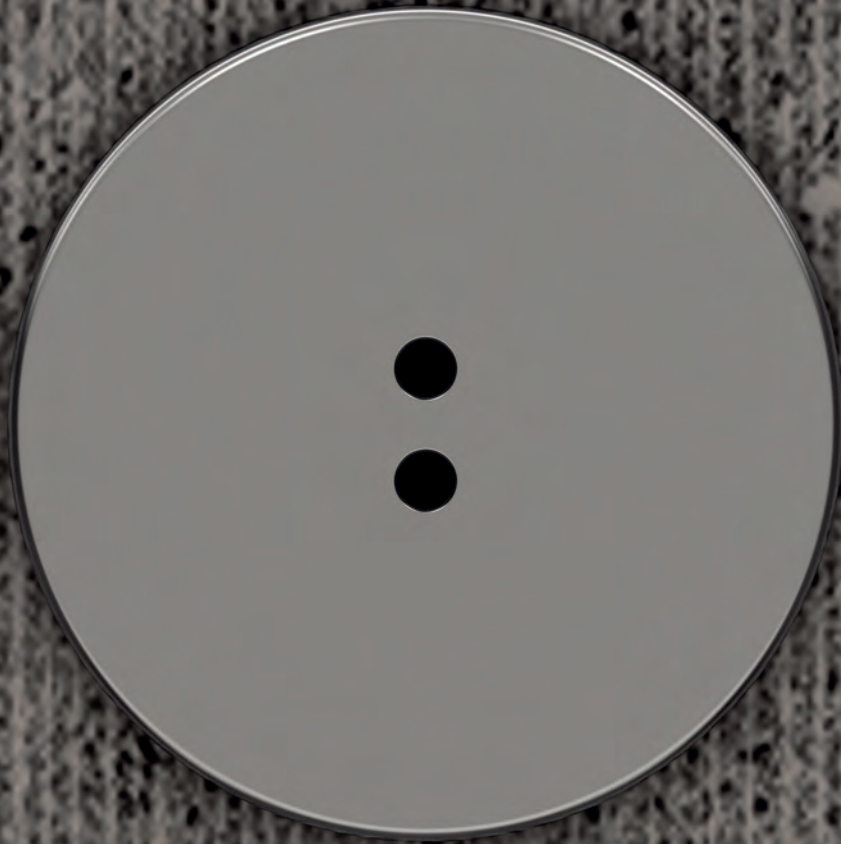

○ GRIFERÍA PARA
INODORO

● TORNEIRAS PARA
INODORO

● RUBINETTI PER WC

◎ ROBINETS POUR
TOILETTE

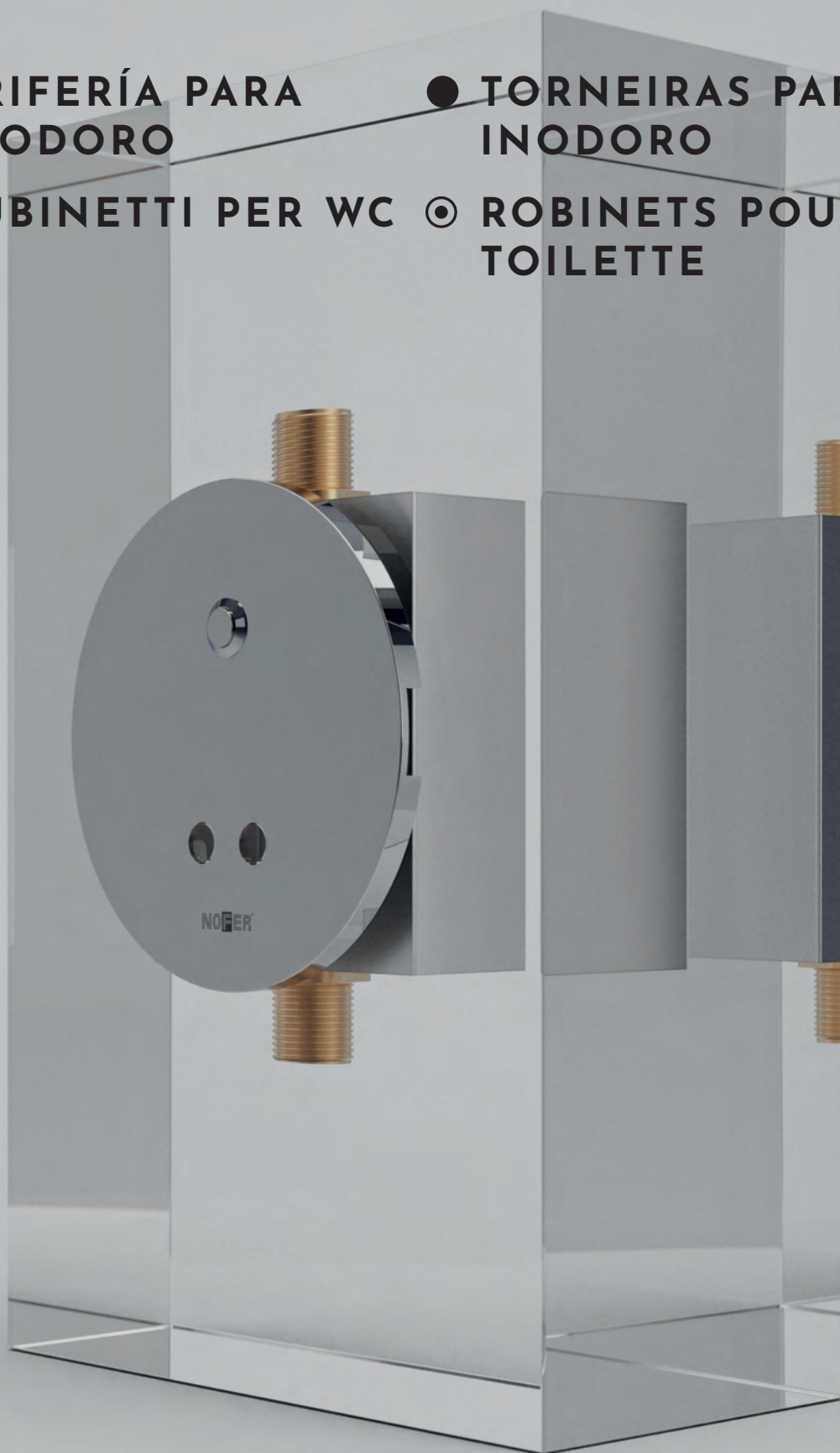

○
**Grifería
para
inodoro**

Adecuado para zonas de alta frecuencia de uso y requisitos higiénicos elevados

Activación mediante sensor de infrarrojos

Operación mediante conexión a red eléctrica utilizando 4 baterías AA como back up de seguridad

Alimentación mediante corriente eléctrica o baterías

Embelecedor de aluminio inyectado cromado bajo la norma EN248. Cuerpo de latón CW617N cromado bajo la norma EN248. Componentes plásticos en POM

Presión de trabajo entre 0,5-6 bar. Presión recomendada 3 bar

Filtro antipartículas

●
**Torneira
para
inodoro**

Adecuado para áreas de uso de alta frecuencia e altos requisitos de higiene

Ativação por sensor infravermelho

Operação por conexão à rede elétrica usando 4 baterias AA como um backup de segurança

Fonte de alimentação por corrente elétrica ou baterias

Guarnição em alumínio injetado cromado segundo a norma EN248. Corpo em latão cromado CW617N de acordo com a norma EN248. Componentes plásticos em POM

Pressão de trabalho entre 0,5-6 bar. Pressão recomendada 3 bar

Filtro anti-particulado

●
**Rubinetteria
per WC**

Adatto per aree ad alta frequenza di utilizzo ed elevati requisiti igienici

Attivazione tramite sensore a infrarossi

Funzionamento tramite connessione alla rete elettrica utilizzando 4 batterie AA come backup di sicurezza

Alimentazione tramite corrente elettrica o batterie

Lunetta di abbellimento in alluminio pressofuso cromato secondo la norma EN248. Struttura d'ottone CW617N cromato secondo la norma EN248. Parti in plastica POM

Pressione di esercizio tra 0,5-6 bar. Pressione consigliata 3 bar

Filtro antiparticolato

⊙
**Robinet
électronique de
chasse d'eau
WC**

Approprié aux zones d'utilisation à haute fréquence et aux exigences d'hygiène élevées

Déclenchement par capteur infrarouge

Fonctionnement par connexion au réseau électrique en utilisant 4 piles AA comme sauve garde de sécurité

Alimentation électrique ou à piles

Cache en aluminium injecté chromé, conforme à la norme EN248. Corps en laiton CW617N, chromé selon la norme EN248. Composants plastiques en POM

Pression de fonctionnement entre 0,5-6 bar. Pression recommandée 3 bars

Filtre antiparticules



○ Grifería electrónica

● Torneria eletrônica

● Rubinetteria elettronica

⊙ Robinet électronique

07291.B

Essentialmatic

- Grifo electrónico para inodoro. Instalación empotrada. Alimentación por baterías o corriente eléctrica
- Rubinetto elettronico per WC. Installazione ad incasso. Alimentato da batterie o corrente elettrica

- Torneira eletrônica para inodoro. Instalação embutida. Alimentado por baterias ou corrente elétrica
- ⊙ Robinet électronique de chasse d'eau WC. Installation encastrée. Alimenté par batteries ou du courant électrique

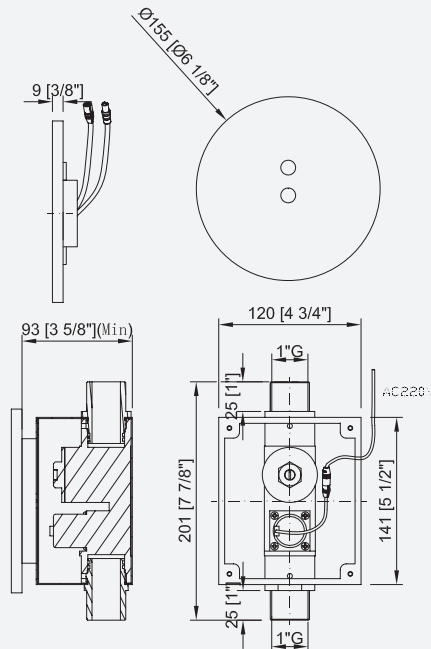

07291.B
255,00 €

07292.B

Luxmatic

- Grifo electrónico para inodoro con activación automática y manual. Instalación empotrada. Alimentación por baterías o corriente eléctrica
- Rubinetto elettronico per WC con attivazione automatica e manuale. Installazione ad incasso. Alimentato da batterie o corrente elettrica

- Torneira eletrônica para inodoro com ativação automática e manual. Instalação embutida. Alimentado por baterias ou corrente elétrica
- ⊙ Robinet électronique de chasse d'eau WC. à déclenchement automatique et manuel. Installation encastrée. Alimenté par batteries ou du courant électrique

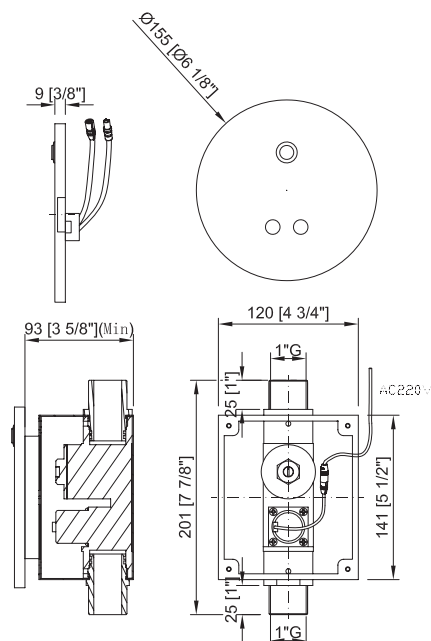

07292.B
280,00 €



07293.B

Essentialmatic

○ Fluxor electrónico para inodoro.
Instalación vista. Alimentación
mediante baterías

● Flussometro elettronico per WC.
Installazione a vista. Alimentato
da batterie

● Fluxor eletrônico para inodoro.
Instalación vista. Alimentado por
baterías

⊙ Chasse d'eau WC électronique.
Installation visible. Alimenté par
batteries

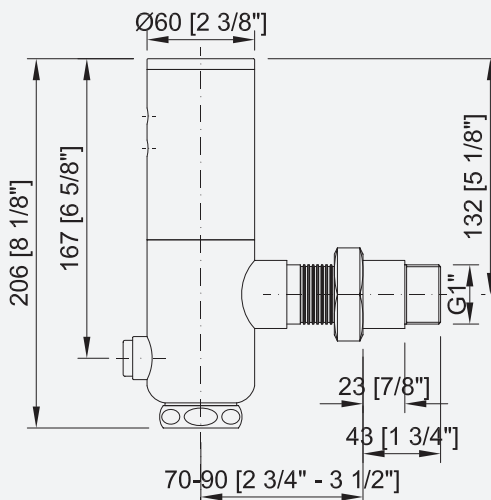

07293.B
292,50 €

07294.B

Luxmatic

○ Fluxor electrónico para inodoro.
Instalación vista. Conectado a
red eléctrica o baterías

● Flussometro elettronico per
WC. Installazione a vista.
Funzionamento connesso alla
rete elettrica o con batterie

● Fluxor eletrônico para inodoro.
Instalación vista. Conectado à
rede elétrica ou baterías

⊙ Chasse d'eau WC électronique,
Installation visible. Connexion
électrique ou à piles.

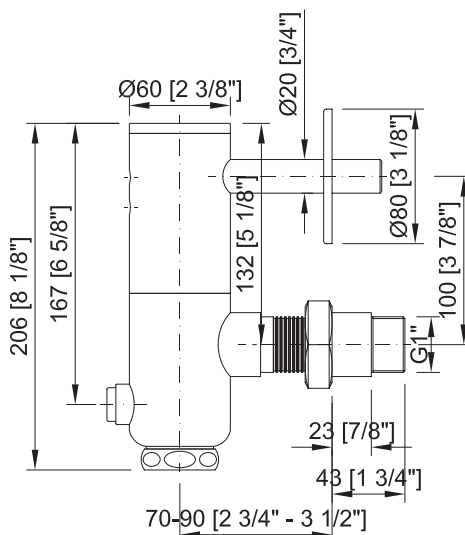

07294.B
340,00 €

- GRIFERÍA
TEMPORIZADA**
- TORNEIRAS
TEMPORIZADA**
- RUBINETTERIA
TEMPORIZZATA**
- ROBINET
TEMPORISÉ**



○ GRIFERÍA SOBRE
ENCIMERA

● TORNEIRAS DE
BANCADA

● RUBINETTI BORDO
LAVABO

◎ ROBINETS SUR
PLAN DE TRAVAIL





Encimera

Cuerpo de latón CW617N cromado. Componentes plásticos en POM

Activación mediante botón pulsador

Tiempo de actuación 7 ± 3 s. Según norma UNE-EN 816

Filtro antipartículas

Temperatura máxima 85°C. Temperatura máxima recomendada 60° C

Presión de trabajo entre 0,5-5 bar. Presión recomendada 3 bar



Bancada

Corpo em latão cromado CW617N. Componentes plásticos em POM

Ativação por botão de pressão

Tempo de ação 7 ± 3 s. De acordo com a norma UNE-EN 816

Filtro anti-particulado

Temperatura máxima 85° C. Temperatura máxima recomendada 60° C

Pressão de trabalho entre 0,5-5 bar. Pressão recomendada 3 bar



Piano lavabo

Corpo in ottone CW617N cromato. Componenti in plastica in POM

Attivazione tramite pulsante

Tempo di azione 7 ± 3 s. Secondo la norma UNE-EN 816

Filtro antiparticolato

Temperatura massima 85° C. Temperatura massima consigliata 60° C

Pressione di esercizio tra 0,5-5 bar. Pressione consigliata 3 bar



Plan de travail

Corps en laiton CW617N chromé. Composant plastiques en POM

Déclenchement par bouton-poussoir

Durée de fonctionnement 7 ± 3 s. Selon la norme UNE-EN 816

Filtre antiparticules

Température maximale 85 °C. Température maximale recommandée 60° C

Pression de fonctionnement entre 0,5-5 bar. Pression recommandée 3 bars



07430.LN

Evotemp



○ Grifo temporizado un agua para lavabo encimera

● Rubinetto temporizzato per lavabo

● Torneira temporizada uma água para lavatório de bancada

◎ Robinet temporisé à une eau pour lavabo

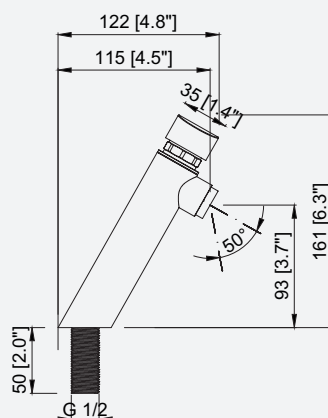

1,89 l/min	07430.LN 61,90 €
3 l/min	07430.EN 65,90 €
6 l/min	07430.N 60,90 €
	97001.07.N 21,20 €



○ Pulsación normal ● Pulsação normal
● Pressione normal ◎ Pression normale



○ Grifería temporizada

● Torneiras temporizada

● Rubinetteria temporizzata

⊙ Robinet temporisé



07420.LN

Protemp

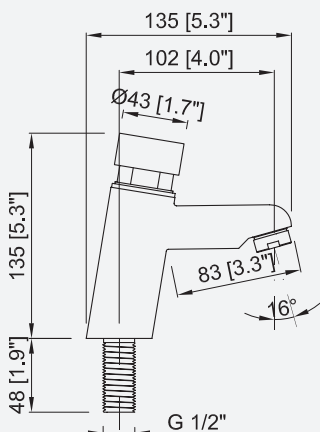

○ Grifo temporizado un agua para lavabo encimera

● Rubinetto temporizzato per lavabo

● Torneira temporizada uma água para lavatório de bancada

⊙ Robinet temporisé à une eau pour lavabo



	1,89 l/min	07420.LN 60,00 €
	3 l/min	07420.EN 64,00 €
	6 l/min	07420.N 59,00 €
		97003.N 29,00 €



07410.LN

Essentialtemp

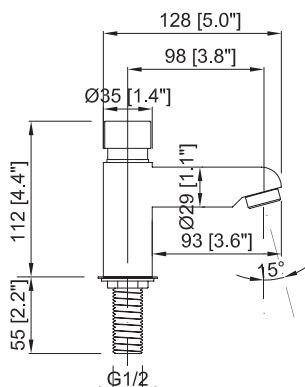

○ Grifo temporizado un agua para lavabo encimera

● Rubinetto temporizzato per lavabo

● Torneira temporizada uma água para lavatório de bancada

⊙ Robinet temporisé à une eau pour lavabo



	1,89 l/min	07410.LN 45,90 €	07410.LA 60,90 €	07410.LS 61,90 €	07410.LR 102,60 €
	3 l/min	07410.EN 49,90 €	07410.EA 64,90 €	07410.ES 66,90 €	07410.ER 113,70 €
	6 l/min	07410.N 44,90 €	07410.A 59,90 €	07410.S 60,90 €	07410.R 101,60 €
		97001.07.N 21,20 €	97001.07.A 24,50 €	97004.US 42,60 €	97004.LR 50,00 €



07400.LN

Essentialtemp

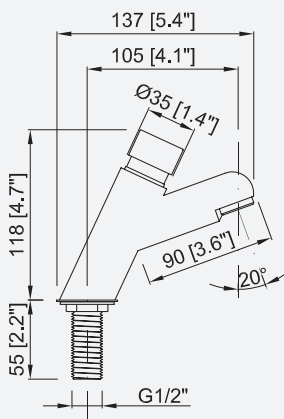

○ Grifo temporizado un agua para lavabo encimera

● Rubinetto temporizzato per lavabo

● Torneira temporizada uma água para lavatório de bancada

⊙ Robinet temporisé à une eau pour lavabo

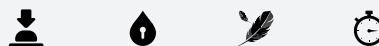

	1,89 l/min	07400.LN 46,40 €	07400.LA 61,40 €	07400.LS 63,40 €	07400.LR 102,20 €
	3 l/min	07400.EN 50,40 €	07400.EA 65,40 €	07400.ES 67,40 €	07400.ER 113,40 €
	6 l/min	07400.N 45,40 €	07400.A 60,40 €	07400.S 62,40 €	07400.R 101,20 €
		97001.07.N 21,20 €	97001.07.A 24,50 €	97004.US 42,60 €	97004.LR 50,00 €



○ Pulsación normal ● Pulsação normal



○ Antiblocaje ● Anti-bloqueo



○ Pulsación suave ● Pulsação suave



○ Tempo ajustable ● Tempo ajustável

● Pressione normal ⊙ Pression normale

● Antibloccaggio ⊙ Anti-verrouillage

● Pressione morbida ⊙ Douce push

● Tempo regolabile ⊙ Temps réglable



07425M.S

Luxtemp

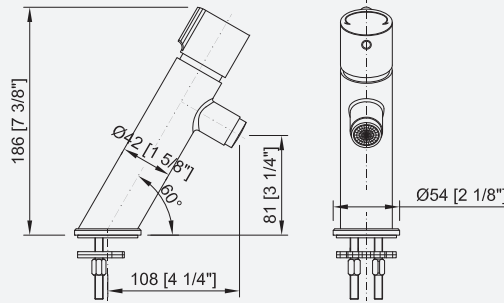

- Grifo temporizado mezclador para lavabo encimera. Mando mezclador en el pulsador
- Torneira temporizada misturadora para lavatório de bancada
- Miscelatore temporizzato per bordo lavabo. Pulsador
- ⊙ Mitigeur temporisé de lavabo à installation sur plan de travail.



N 6 l/min

07425M.S
170,00 €

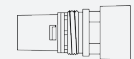

97440.30.S
30,00 €



07430M.LN

Evotemp

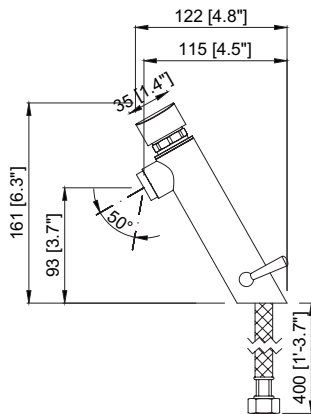

- Grifo temporizado mezclador para lavabo encimera
- Torneira temporizada misturadora para lavatório de bancada
- Miscelatore temporizzato per bordo lavabo
- ⊙ Mitigeur temporisé de lavabo à installation sur plan de travail



1,89 l/min

07430M.LN
75,90 €

3 l/min

07430M.EN
79,90 €

N 6 l/min

07430M.N
74,90 €

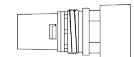

97001.07.N
21,20 €



07420M.LN

Protemp

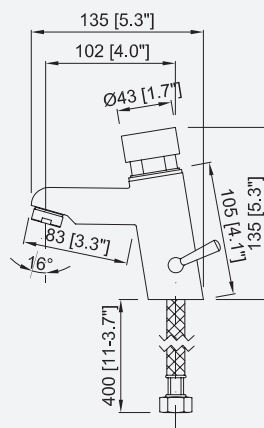

- Grifo temporizado mezclador para lavabo encimera
- Torneira temporizada misturadora para lavatório de bancada
- Miscelatore temporizzato per bordo lavabo
- ⊙ Mitigeur temporisé de lavabo à installation sur plan de travail



1,89 l/min

07420M.LN
74,80 €

3 l/min

07420M.EN
78,80 €

N 6 l/min

07420M.N
73,80 €



97003.N
29,00 €



○ Grifería temporizada

● Torneiras temporizada

● Rubinetteria temporizzata

⊙ Robinet temporisé

○
Mural

Cuerpo de latón CW617N cromado. Componentes plásticos en POM

Activación mediante botón pulsador

Tiempo de actuación 7 ± 3 s. Según norma UNE-EN 816

Filtro antipartículas

Temperatura máxima 85°C. Temperatura máxima recomendada 60° C

Presión de trabajo entre 0,5-5 bar. Presión recomendada 3 bar

●
Mural

Corpo em latão cromado CW617N. Componentes plásticos em POM

Ativação por botão de pressão

Tempo de ação 7 ± 3 s. De acordo com a norma UNE-EN 816

Filtro anti-particulado

Temperatura máxima 85° C. Temperatura máxima recomendada 60° C

Pressão de trabalho entre 0,5-5 bar. Pressão recomendada 3 bar

●
A parete

Corpo in ottone CW617N cromato. Componenti in plastica in POM

Attivazione tramite pulsante

Tempo di azione 7 ± 3 s. Secondo la norma UNE-EN 816

Filtro antiparticolato

Temperatura massima 85° C. Temperatura massima consigliata 60° C

Pressione di esercizio tra 0,5-5 bar. Pressione consigliata 3 bar

⊙
Mural

Corps en laiton CW617N chromé. Composant plastiques en POM

Déclenchement par bouton-poussoir

Durée de fonctionnement 7 ± 3 s. Selon la norme UNE-EN 816

Filtre antiparticules

Température maximale 85 °C. Température maximale recommandée 60° C

Pression de fonctionnement entre 0,5-5 bar. Pression recommandée 3 bars



07480.LN

Evotemp

○ Grifo largo mural temporizado un agua para lavabo

● Torneira longa mural temporizada uma água para lavatório

● Rubinetto lungo a parete temporizzato per lavabo

⊙ Robinet long mural temporisé à une eau pour lavabo

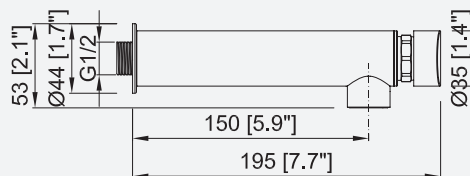

1,89 l/min **07480.LN**
54,50 €

3 l/min **07480.EN**
58,50 €

6 l/min **07480.N**
53,50 €

97001.07.N
21,20 €





07450.LN

Evotemp

○ Grifo mural temporizado un agua para lavabo

● Torneira de parede cronometrada para lavatório

● Rubinetto a parete temporizzato ad una acqua per lavabo

⊙ Robinet mural temporisé à une eau pour lavabo

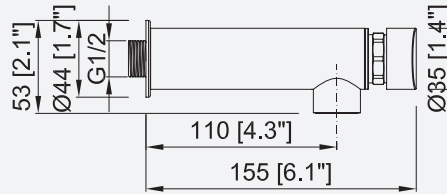

1,89 l/min	07450.LN 43,60 €
3 l/min	07450.EN 47,60 €
6 l/min	07450.N 42,60 €
	97001.07.N 21,20 €



07440.LN

Essentialtemp

○ Grifo mural temporizado un agua para lavabo

● Torneira de parede cronometrada para lavatório

● Rubinetto a parete temporizzato ad una acqua per lavabo

⊙ Robinet mural temporisé à une eau pour lavabo

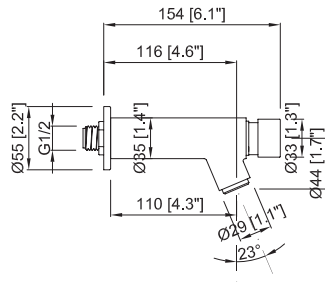

1,89 l/min	07440.LN 40,70 €	07440.LA 55,70 €	07440.LS 57,70 €	07440.LR 106,00 €
3 l/min	07440.EN 44,70 €	07440.EA 59,70 €	07440.ES 61,70 €	07440.ER 107,60 €
6 l/min	07440.N 39,70 €	07440.A 54,70 €	07440.S 56,70 €	07440.R 105,00 €
	97001.07.N 21,20 €	97001.07.A 24,50 €	97004.US 42,60 €	97004.LR 50,00 €

07490.N

Essentialtemp

○ Grifo mural temporizado un agua para lavabo. Instalación vista

● Torneira de parede com temporizador de uma água para lavatório. Instalação visível

● Rubinetto temporizzato a parete per lavabo. Installazione visibile

⊙ Robinet mural temporisé à une eau pour lavabo. Installation visible

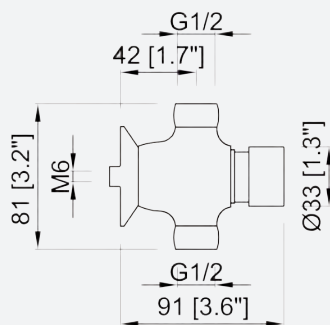

6 l/min	07490.N 41,70 €	07490.A 56,70 €	07490.S 58,70 €	07490.R 87,30 €
	97001.07.N 21,20 €	97001.07.A 24,50 €	97004.US 42,60 €	97004.LR 50,00 €



○ Pulsación normal ● Pulsação normal



○ Antiblocaje ● Anti-bloqueio



○ Pulsación suave ● Pulsação suave



○ Tiempo ajustable ● Tempo ajustável

● Pressione normal ⊙ Pression normale

● Antibloccaggio ⊙ Anti-verrouillage

● Pressione morbida ⊙ Douce push

● Tempo regolabile

⊙ Temps réglable



Grifería temporizada

Torneiras temporizada

Rubinetteria temporizzata

Robinet temporisé

Instalación empotrada

Cuerpo de latón CW617N cromado. Componentes plásticos en POM

Activación mediante botón pulsador

Tiempo de actuación 7 ± 3 s. Según norma UNE-EN 816

Filtro antipartículas

Temperatura máxima 85°C. Temperatura máxima recomendada 60° C

Presión de trabajo entre 0,5-5 bar. Presión recomendada 3 bar

Instalação encastrada

Corpo em latão cromado CW617N. Componentes plásticos em POM

Ativação por botão de pressão

Tempo de ação 7 ± 3 s. De acordo com a norma UNE-EN 816

Filtro anti-particulado

Temperatura máxima 85° C. Temperatura máxima recomendada 60° C

Pressão de trabalho entre 0,5-5 bar. Pressão recomendada 3 bar

Installazione ad incasso

Corpo in ottone CW617N cromato. Componenti in plastica in POM

Attivazione tramite pulsante

Tempo di azione 7 ± 3 s. Secondo la norma UNE-EN 816

Filtro antiparticolato

Temperatura massima 85° C. Temperatura massima consigliata 60° C

Pressione di esercizio tra 0,5-5 bar. Pressione consigliata 3 bar

Installation encastrée

Corps en laiton CW617N chromé. Composant plastiques en POM

Déclenchement par bouton-poussoir

Durée de fonctionnement 7 ± 3 s. Selon la norme UNE-EN 816

Filtre antiparticules

Température maximale 85 °C. Température maximale recommandée 60° C

Pression de fonctionnement entre 0,5-5 bar. Pression recommandée 3 bars



07570.LN Essentialtemp

○ Grifo mural temporizado un agua para lavabo. Instalación empotrada

● Torneira mural temporizada para urinol, instalação nivelada empotrada

● Rubinetto temporizzato a parete per orinatoio, installazione ad incasso

⊙ Robinet mural temporisé pour urinoir installation encastrée

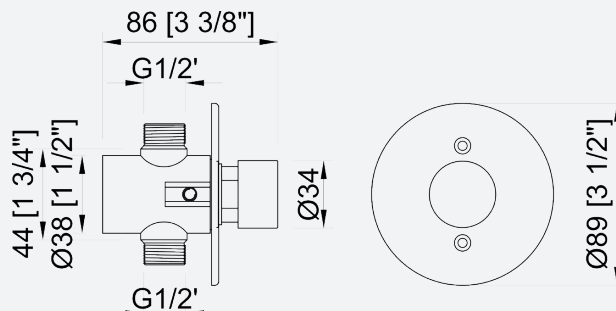

 1,89 l/min	07570.LN 42,40 €	07570.LA 57,40 €	07570.LS 59,40 €	07570.LR 92,00 €
 6 l/min	07570.N 41,40 €	07570.A 56,40 €	07570.S 58,40 €	07570.R 91,00 €
 21,20 €	97001.07.N 21,20 €	97001.07.A 24,50 €	97004.US 42,60 €	97004.LR 50,00 €

07460.N Essentialtemp



○ Grifo mural temporizado un agua para lavabo, instalación en panel chapa

● Torneira mural temporizada uma água para lavatório, instalação em painel chapa

● Rubinetto a parete temporizzato per lavabo, installazione pannello di lamiera

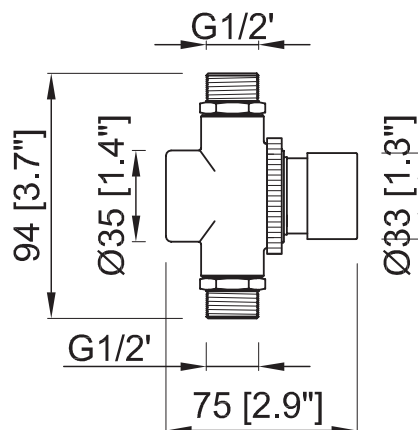
⊙ Robinet mural temporisé à une eau pour lavabo installation sur panneau d'acier



 6 l/min	07460.N 33,50 €	07460.A 48,50 €	07460.S 50,50 €	07460.R 83,50 €
 21,20 €	97001.07.N 21,20 €	97001.07.A 24,50 €	97004.US 42,60 €	97004.LR 50,00 €



○ Pulsación normal ● Pulsação normal



○ Antiblocaje ● Anti-bloqueio



○ Pulsación suave ● Pulsação suave



○ Tiempo ajustable ● Tempo ajustável

● Pressione normal ⊙ Pression normale

● Antibloccaggio ⊙ Anti-verrouillage

● Pressione morbida ⊙ Douce push

● Tempo regolabile ⊙ Temps réglable



○ Grifería temporizada

● Torneiras temporizada

● Rubinetteria temporizzata

⊙ Robinet temporisé

Palanca

Cuerpo de latón CW617N cromado. Componentes plásticos en POM

Activación mediante palanca

Tiempo de actuación 7 ± 3 s. Según norma UNE-EN 816

Filtro antipartículas

Temperatura máxima 85°C. Temperatura máxima recomendada 60° C

Presión de trabajo entre 0,5-5 bar. Presión recomendada 3 bar

Pavanca

Corpo em latão cromado CW617N. Componentes plásticos em POM

Ativação por alavanca

Tempo de ação 7 ± 3 s. De acordo com a norma UNE-EN 816

Filtro anti-particulado

Temperatura máxima 85° C. Temperatura máxima recomendada 60° C

Pressão de trabalho entre 0,5-5 bar. Pressão recomendada 3 bar

Leva

Corpo in ottone CW617N cromato. Componenti in plastica in POM

Attivazione a leva

Tempo di azione 7 ± 3 s. Secondo la norma UNE-EN 816

Filtro antiparticolato

Temperatura massima 85° C. Temperatura massima consigliata 60° C

Pressione di esercizio tra 0,5-5 bar. Pressione consigliata 3 bar

Levier

Corps en laiton CW617N chromé. Composant plastiques en POM

Déclenchement grâce au levier

Durée de fonctionnement 7 ± 3 s. Selon la norme UNE-EN 816

Filtre antiparticules

Température maximale 85 °C. Température maximale recommandée 60° C

Pression de fonctionnement entre 0,5-5 bar. Pression recommandée 3 bars



07430MP.LS

Evolever

○ Grifo mezclador temporizado para lavabo encimera, activado por palanca

● Torneira misturadora temporizada para lavatório de bancada, ativada por alavanca

● Miscelatore temporizzato per lavabo, comando a leva

⊙ Mitigeur temporisé sur plan de travail pour lavabo, fonctionne avec levier

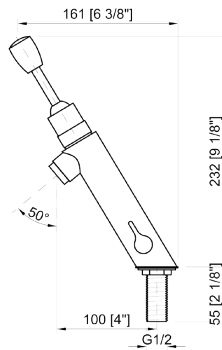

1,89 l/min	07430MP.LS 120,90 €
3 l/min	07430MP.ES 124,90 €
6 l/min	07430MPS 119,90 €
	97001.P 42,50 €



07430P.LS

Evolever

○ Grifo temporizado un agua para lavabo encimera, activado por palanca

● Torneira temporizada uma água para lavatório de bancada, ativada por alavanca

● Rubinetto temporizzato per lavabo, comando a leva

⊙ Robinet temporisé à une eau sur plan de travail pour lavabo, fonctionne avec levier

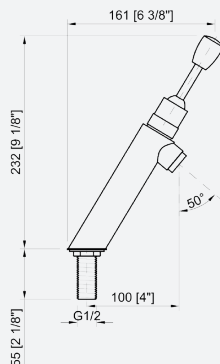

1,89 l/min	07430P.LS 105,90 €
3 l/min	07430P.ES 109,90 €
6 l/min	07430P.S 104,90 €
	97001.P 42,50 €



○ Pulsación suave

● Pulsação suave

● Pressione morbida

⊙ Douce push



07400P.LS Essentialtemp



- Grifo temporizado un agua para lavabo encimera, activado por palanca
- Rubinetto temporizzato per lavabo, comando a leva

- Torneira temporizada uma água para lavatório de bancada, ativada por alavanca
- Robinet temporisé à une eau sur plan de travail pour lavabo, fonctionne avec levier

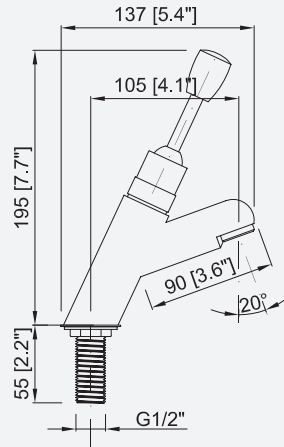

1,89 l/min	07400P.LS 95,00 €
3 l/min	07400P.ES 99,00 €
6 l/min	07400P.S 94,00 €
	97001.P 42,50 €



07410P.LS Essentialtemp



- Grifo temporizado un agua para lavabo encimera, activado por palanca
- Rubinetto temporizzato per lavabo, comando a leva

- Torneira temporizada uma água para lavatório de bancada, ativada por alavanca
- Robinet temporisé à une eau sur plan de travail pour lavabo, fonctionne avec levier

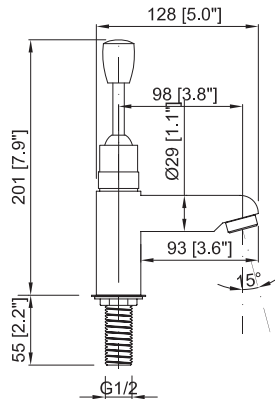

1,89 l/min	07410P.LS 95,00 €
3 l/min	07410P.ES 99,00 €
6 l/min	07410P.S 94,00 €
	97001.P 42,50 €



07440P.LS Essentialtemp



- Grifo mural temporizado un agua para lavabo, activado por palanca
- Rubinetto temporizzato per lavabo, comando a leva

- Torneira mural temporizada uma água para lavatório, ativada por alavanca
- Robinet mural temporisé à une eau sur plan de travail pour lavabo, fonctionne avec levier

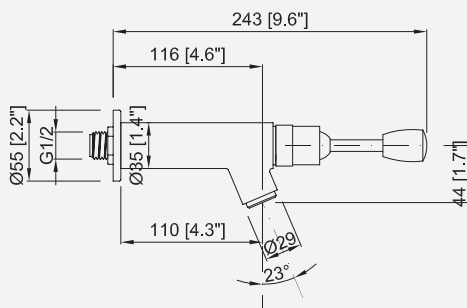

1,89 l/min	07440P.LS 90,00 €
3 l/min	07440P.ES 94,00 €
6 l/min	07440P.S 89,00 €
	97001.P 42,50 €



○ Pulsación suave

● Pulsação suave

● Pressione morbida

○ Douce push



○ Grifería temporizada

● Torneiras temporizada

● Rubinetteria temporizzata

⊙ Robinet temporisé

○ Caños lavabo

Cuerpo de latón CW617N cromado bajo la norma EN 248

● Bicos de bacia

Corpo de latão CW617N, cromado baixo a norma EN 248

● Bocchello lavabo

Corpo in ottone CW617N cromato conforme alla norma EN 248

⊙ Bec col de cygne lavabo

Corps en laiton chromé CW617N selon la norme EN 248

07008.B

○ Caño mural para lavamanos

● Cano de parede para pias

● Bocchello a parete per lavabo

⊙ Bec verseur mural pour lave-mains

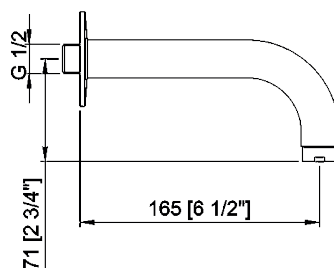
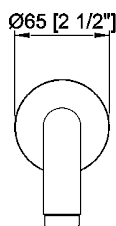

07008.B
57,50 €

07009.B

○ Caño encimera para lavamanos

● Cano de parede para pias

● Bocchello a parete per lavabo

⊙ Bec verseur sur plan de travail pour lave-mains

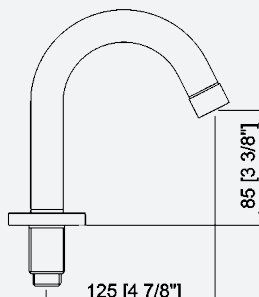
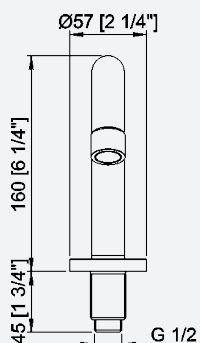

07009.B
101,00 €



07010.B

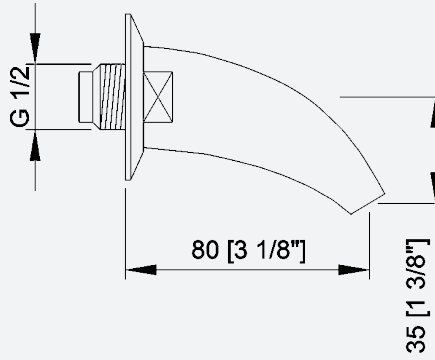

○ Caño curvo mural

● Bocchello curvo a parete

● Bico curvo de parede

⊙ Bec mural courbé

07010.B
46,50 €

07022.B

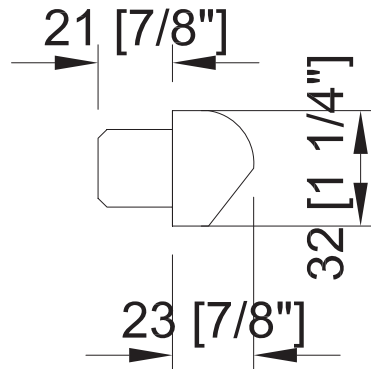
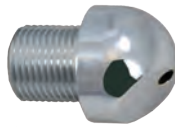

○ Caño antivandálico

● Bocchello antivandalo

● Bico anti-vandalismo

⊙ Bec antivandalisme

07022.B
29,50 €

○ GRIFERÍA PARA
URINARIO

● TORNEIRAS PARA
URINOL

● RUBINETTI PER
ORINATOIO

◎ RUBINETS POUR
URINOIR





○ Grifería para urinario

Cuerpo de latón CW617N cromado. Componentes plásticos en POM

Tiempo de actuación **7±3 s**

Filtro antipartículas

Temperatura máxima 85°C. Temperatura máxima recomendada 60° C

Presión de trabajo entre 0,5-6 bar. Presión recomendada 3 bar

● Torneira para urinol

Corpo em latão cromado CW617N. Componentes plásticos em POM

Tempo de atuação **7 ± 3 s**

Filtro anti-particulado

Temperatura máxima 85° C. Temperatura máxima recomendada 60° C

Pressão de trabalho entre 0,5-6 bar. Pressão recomendada 3 bar

● Rubinetteria per orinatoio

Corpo in ottone CW617N cromato. Componenti in plastica in POM

Tempo di prestazione **7±3 s**

Filtro antiparticolato

Temperatura massima 85° C. Temperatura massima consigliata 60° C

Pressione di esercizio tra 0,5-6 bar. Pressione consigliata 3 bar

⊙ Robinet pour urinoir

Corps en laiton CW617N chromé. Composant plastiques en POM

Durée de fonctionnement **7 ± 3 s**

Filtre antiparticules

Température maximale 85 °C. Température maximale recommandée 60° C

Pression de fonctionnement entre 0,5-6 bar. Pression recommandée 3 bars

07091.B

Protemp



○ Fluxor temporizado mural 3/4" G para urinario

● Flussometro temporizzato a parete 3/4" G per orinatoio

● Válvula de descarga temporizada mural 3/4" G de urinol

⊙ Robinet de chasse temporisé mural 3/4" G pour urinoir

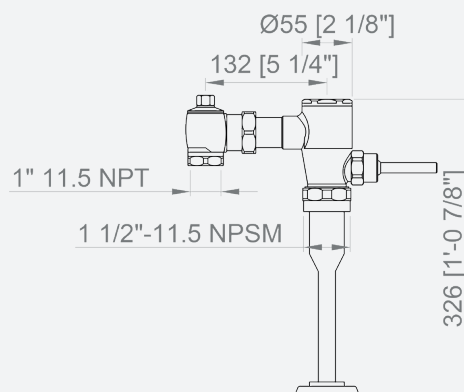

07091.B
130,00 €



○ Grifería temporizada

● Torneiras temporizada

● Rubinetteria temporizzata

⊙ Robinet temporisé



07510.LN Essentialtemp

NEW • NUEVO
NOUVEAU • NUOVO



○ Grifo temporizado mural para urinario, instalación vista

● Torneira mural temporizada para urinol, instalação exposta

● Rubinetto temporizzato a parete per orinatoio

⊙ Robinet mural temporisé pour urinoir installation visible

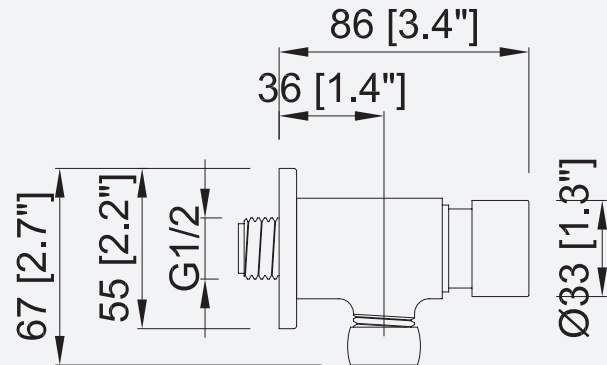

1,89 l/min	07510.LN 33,00 €	07510.LA 48,00 €	07510.LS 50,00 €
6 l/min	07510.N 32,00 €	07510.A 47,00 €	07510.S 49,00 €
	97001.07.N 21,20 €	97001.07.A 24,50 €	97004.US 42,60 €



07570.LN Essentialtemp

NEW • NUEVO
NOUVEAU • NUOVO



○ Grifo mural temporizado un agua para urinario. Instalación empotrada

● Torneira temporizada para urinol, instalação embutida

● Rubinetto temporizzato per orinatoio, installazione ad incasso

⊙ Robinet pour urinoir, installation encastrée

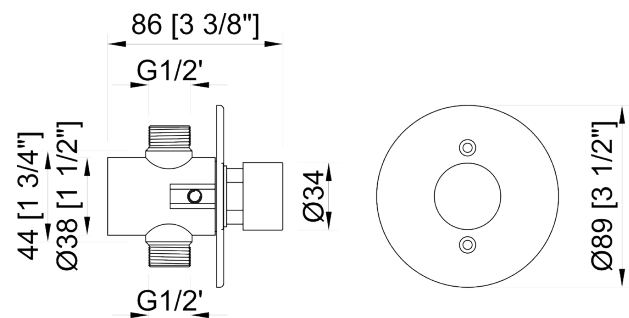

1,89 l/min	07570.LN 42,40 €	07570.LA 57,40 €	07570.LS 59,40 €
6 l/min	07570.N 41,40 €	07570.A 56,40 €	07570.S 58,40 €
	97001.07.N 21,20 €	97001.07.A 24,50 €	97004.US 42,60 €



○ Pulsación normal

● Pulsação normal



○ Antiblocaje

● Anti-bloqueio



○ Pulsación suave

● Pulsação suave

● Pressione normal

⊙ Pression normale

● Antibloccaggio



○ Pressione morbida

⊙ Douce push



07590.B

- Enlace recto semi flexible para urinario
- Tubo dritto semi flessibile per orinatoio

- Tubo reto semi-flexível para torneira de mictório
- ⊙ Tube droit semi-flexible pour urinoir

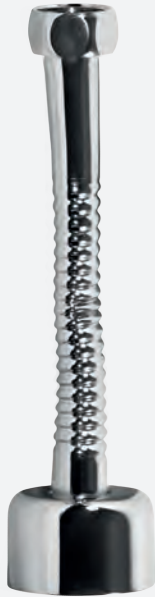

07590.B
11,80 €

07591.B

- Enlace curvo para urinario
- Tubo dritto per orinatoio

- Tubo dobrado para torneira de mictório
- ⊙ Tube courbé pour urinoir

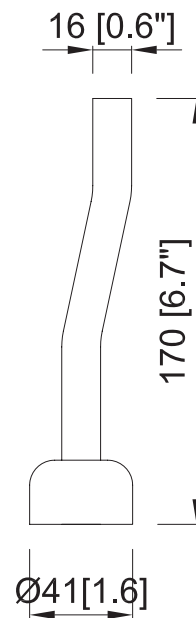

07591.B
11,60 €

○ GRIFERÍA PARA
INODORO

● TORNEIRAS PARA
INODORO

● RUBINETTI
PER WC

⊙ ROBINETS POUR
TOILETTE





Instalación vista

Cuerpo de latón CW617N cromado bajo la norma EN 248. Componentes plásticos en POM

Tiempo de actuación 8 a 3 s

Presión de trabajo entre 2-6 bar. Presión recomendada 3 bar



Instalação visível

Corpo de latão CW617N, cromado de acordo com a norma EN 248. Componentes de plástico POM

Tempo de atuação de 8 a 3 s

Pressão de trabalho entre 2-6 bar. Pressão recomendada 3 bar



Installazione a vista

Corpo in ottone cromato CW617N secondo EN 248. Componenti in plastica in POM

Tempo di esecuzione da 8 a 3 s

Pressione di esercizio tra 2-6 bar. Pressione consigliata 3 bar



Installation visible

Corps en laiton CW617N chromé selon la norme EN 248. Composants plastiques en POM

Durée de fonctionnement 8 a 3 s

Pression de fonctionnement entre 2-6 bar. Pression recommandée 3 bar

07092.B

Protemp



○ Fluxor temporizado mural 1" G para inodoro

● Flussometro temporizzato a parete 1" G per inodoro

● Válvula de descarga temporizada mural 1" G para inodoro

⊙ Robinet de chasse temporisé mural 1" G pour toilette

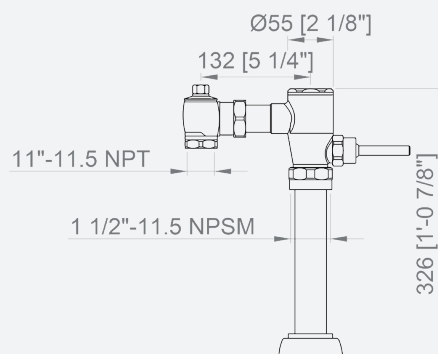

07092.B
150,00 €



○ Grifería temporizada

● Torneiras temporizada

● Rubinetteria temporizzata

⊙ Robinet temporisé

07078.B

Luxtemp



○ Fluxor temporizado mural 3/4" - 1" G con llave de paso

● Flussometro temporizzato a parete 3/4" e 1" G con rubinetto di arresto

● Válvula de descarga temporizada mural, torneira de passagem 3/4" e 1" G

⊙ Robinet de chasse temporisé mural 3/4" et 1" G

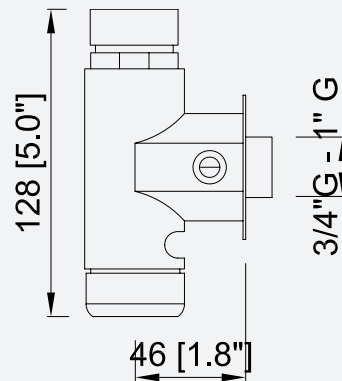

07078.B
75,00 €

07096.B

Essentialtemp



○ Fluxor palanca temporizado mural 3/4" - 1" G con llave de paso

● Flussometro con leva temporizzato a parete 3/4" - 1" G con rubinetto di chiusura

● Válvula de descarga temporizada de parede 3/4" - 1" G com torneira de passagem

⊙ Robinet de chasse d'eau à levier temporisé mural 3/4" - 1" G avec vanne d'arrêt

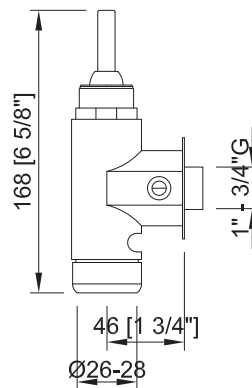

07096.B
75,00 €

07098.B

Essentialtemp



○ Fluxor palanca temporizado mural 3/4" - 1" G

● Flussometro con leva temporizzato a parete 3/4" - 1" G

● Válvula de descarga temporizada de parede 3/4" - 1" G

⊙ Robinet de chasse d'eau à levier temporisé murale 3/4" - 1" G

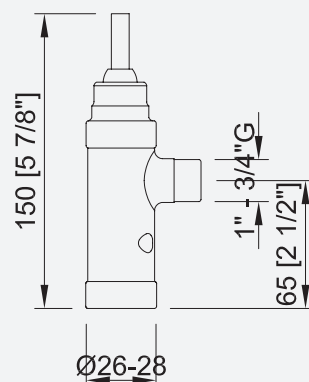

07098.B
59,00 €



07079.B

Luxtemp



○ Fluxor temporizado mural 3/4" - 1"G

● Flussometro temporizzato a parete 3/4" - 1"G

● Válvula de descarga temporizada de parede 3/4" - 1"G

● Robinet de chasse d'eau temporisé mural 3/4" - 1"G

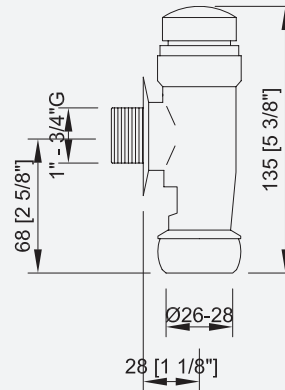

07079.B
59,00 €

07086.52.B



○ Tubo de descarga 52 cm, Ø 28 mm

● Tubo di scarico 52 cm, Ø 28 mm

● Tubo de descarga 52 cm, Ø 28 mm

● Tubo de chasse 52 cm, Ø 28 mm

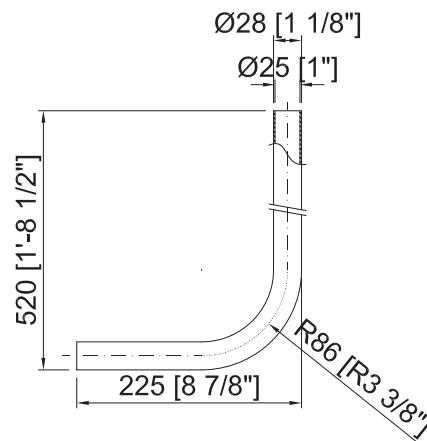

07086.52.B
39,00 €

07086.60.B



○ Tubo de descarga 60 cm, Ø 28 mm

● Tubo di scarico 60 cm, Ø 28 mm

● Tubo de descarga 60 cm, Ø 28 mm

● Tubo de chasse 60 cm, Ø 28 mm

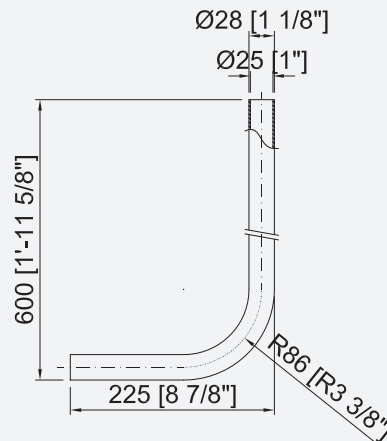

07086.60.B
40,00 €



○ Grifería temporizada

● Torneiras temporizada

● Rubinetteria temporizzata

⊙ Robinet temporisé

07093.B



○ Racor de unión WC

● Racor de unión WC

● Raccordo per WC

⊙ Raccord union WC

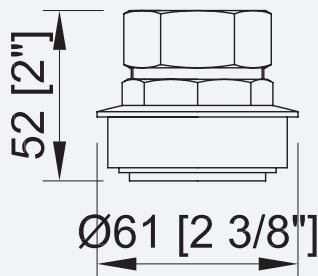

07093.B
42,00 €

07094.B



○ Abrazadera para tubo de descarga.
Para fluxores 07078.B, 07079.B,
07096.B y 07098.B

● Braçadeira para tubo de descarga.
Para fluxores 07078.B, 07079.B,
07096.B e 07098.B

● Morsetto per tubo di scarico.
Per flussometri 07078.B, 07079.B,
07096.B e 07098.B

⊙ Collier de fixation à tube. Pur robinets
de chasse 07078.B, 07079.B, 07096.B
et 07098.B

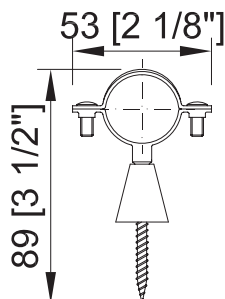

07094.B
9,50 €

97180

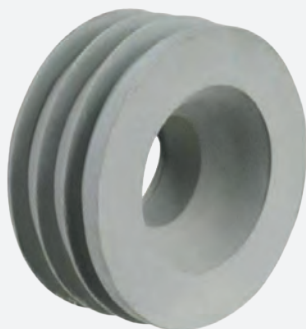

○ Racor de conexión para WC

● Racor de conexão para WC

● Raccordo per WC

⊙ Raccord pour WC

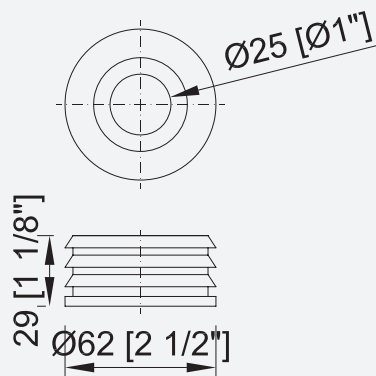

97180
6,00 €



07095.B

○ Abrazadera para tubo de descarga.
Para fluxores 07078.B, 07079.B,
07096.B y 07098.B

● Braçadeira para tubo de descarga.
Para fluxores 07078.B, 07096.B,
07098.B e 07079

● Morsetto per tubo di scarico . Per
flussometri 07078.B, 07079.B, 07096.B
e 07098.B

⊙ Collier de fixation à tube. Pour robinet
de chasse 07078.B, 07079.B, 07096.B
et 07098.B

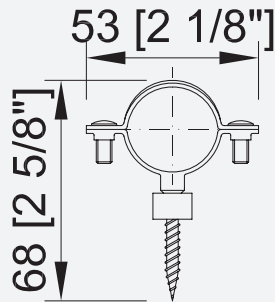

07095.B
9,50 €

07099.B

○ Conjunto de pistón para toda
la gama de fluxores

● Conjunto de pistão para toda
a gama de fluxantes

● Set pistone per l'intera gamma
di flussometri

⊙ Ensemble de piston pour toute
la gamme de robinets de
chasse

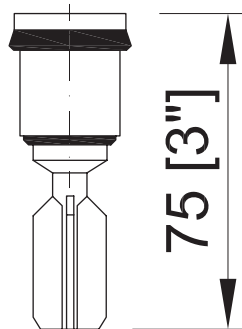

07099.B
9,50 €

97838

○ Racor de unión para tubo de
Ø 32 mm

● Racor de união para tubo de
Ø 32 mm

● Raccordo per tubo Ø 32 mm

⊙ Raccord union pour tube Ø
32 mm



97838
15,00 €



○ Grifería temporizada

● Torneiras temporizada

● Rubinetteria temporizzata

⊙ Robinet temporisé

○ Instalación empotrada

Cuerpo de latón CW617N cromado bajo la norma EN 248. Componentes plásticos en POM

Tiempo de actuación 8 a 3 s

Presión de trabajo entre 6-2 bar. Presión recomendada 3 bar

● Instalação embutida

Corpo de latão CW617N, cromado de acordo com a norma EN 248. Componentes de plástico POM

Tempo de atuação de 8 a 3 s

Pressão de trabalho entre 6-2 bar. Pressão recomendada 3 bar

● Installazione ad incasso

Corpo in ottone cromato CW617N secondo EN 248. Componenti in plastica in POM

Tempo di esecuzione da 8 a 3 s

Pressione di esercizio tra 6-2 bar. Pressione consigliata 3 bar

⊙ Installation encastrée

Corps en laiton CW617N chromé selon la norme EN 248. Composants plastiques en POM

Durée de fonctionnement 8 a 3 s

Pression de fonctionnement entre 6-2 bar. Pression recommandée 3 bar

07076.34.B Essentialtemp



○ Fluxor temporizado mural empotrado 3/4"G

● Flussometro temporizzato ad incasso 3/4"G

● Válvula de descarga temporizada embutida na parede 3/4"G

⊙ Robinet de chasse temporisé mural encastré 3/4"G

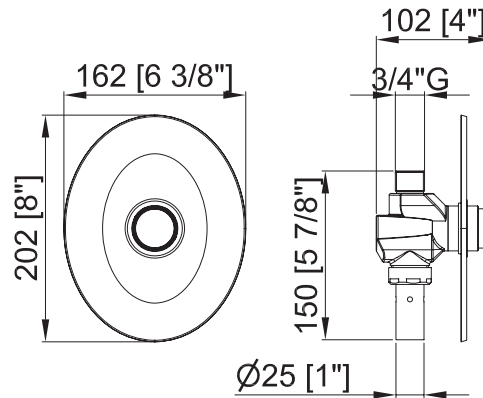

07076.34.B
217,00 €

07076.1.B Essentialtemp



○ Fluxor temporizado mural empotrado 1"G

● Flussometro temporizzato da incasso a parete 1"G

● Válvula descarga antivandalismo 1"G

⊙ Chasse temporisée murale, encastrée 1"G

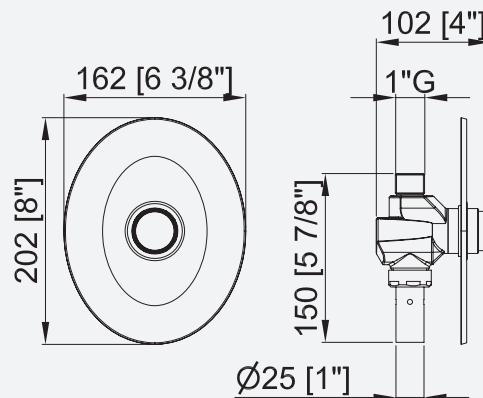

07076.1.B
225,50 €



07083.28.B

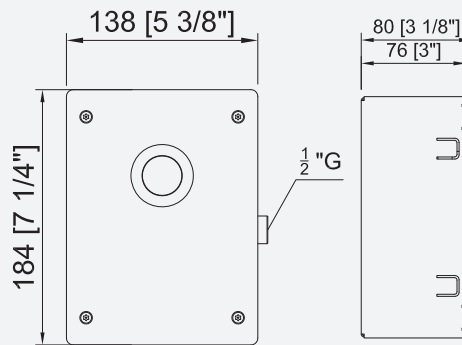

○ Fluxor temporizado mural entrada 1/2"G sin llave de paso. Instalación encastrada. Conexión 28 mm

● Flussometro temporizzato a parete, ingresso 1/2"G senza valvola di intercettazione. Installazione ad incasso. Connessione 28 mm

● Fluxo temporizado de parede entrada 1/2"G sem chave de passo. Instalação embutida. Conexão 28 mm

⊙ Robinet de chasse temporisé mural 1/2"G sans vanne d'arrêt. Installation encastrée. Connexion 28 mm

07083.28.B
195,00 €

07083.32.B

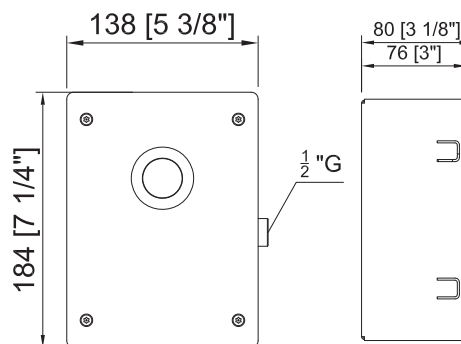

○ Fluxor temporizado mural entrada 1/2"G sin llave de paso. Instalación encastrada. Conexión 32 mm

● Flussometro temporizzato a parete, ingresso 1/2"G senza valvola di intercettazione. Installazione ad incasso. Connessione 32 mm

● Fluxo temporizado de parede entrada 1/2"G sem chave de passo. Instalação embutida. Conexão 32 mm

⊙ Robinet de chasse temporisé mural 1/2"G sans vanne d'arrêt. Installation encastrée. Connexion 32 mm

07083.32.B
205,00 €

○ GRIFERÍA PARA
DUCHA

● RUBINETTI PER
DOCCIA

● TORNEIRAS PARA
DUCHE

◎ ROBINETS POUR
DOUCHE

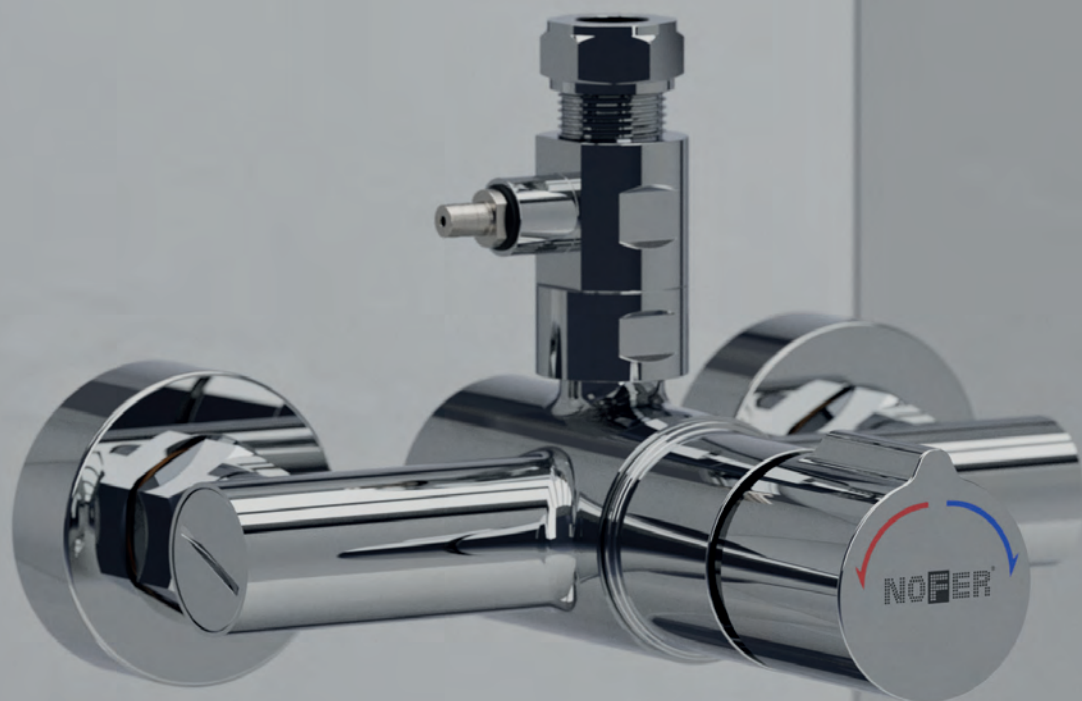



Mural

Cuerpo de latón CW617N cromado. Componentes plásticos en POM

Presión de trabajo entre 6-1 bar. Presión recomendada 3 bar

Filtro antipartículas

Tiempo de actuación 20 ± 10 s



Mural

Corpo em latão cromado CW617N. Componentes plásticos em POM

Pressão de trabalho entre 6-1 bar. Pressão recomendada 3 bar

Filtro anti-particulado

Tempo de atuação de 20 ± 10 s



A parete

Corpo in ottone CW617N cromato. Componenti in plastica in POM

Pressione di esercizio tra 6-1 bar. Pressione consigliata 3 bar

Filtro antiparticolato

Tempo di prestazione 20 ± 10 s



Mural

Corps en laiton CW617N chromé. Composant plastiques en POM

Pression de fonctionnement entre 6-1 bar. Pression recommandée 3 bar

Filtre antiparticules

Durée de fonctionnement 20 ± 10 s



07610.LN Essentialtemp

NEW • NUEVO • NOUVEAU



○ Grifo temporizado un agua para ducha, instalación vista

● Rubinetto temporizzato per doccia, installazione a vista

● Torneira temporizada, instalação exposta

◎ Robinet temporisé une eau pour douche, installation visible

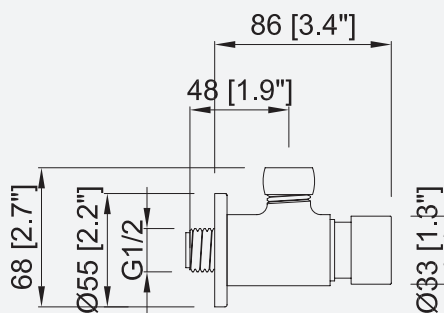

6 l/min

07610.LN
38,50 €

07610.LA
53,50 €

07610.LS
55,50 €

07610.LR
82,00 €



97001.25.N
29,60 €

97001.25.A
32,90 €

97004.DS
46,00 €

97004.DR
60,00 €



○ Pulsación normal ● Pulsação normal



○ Antiblocaje ● Anti-bloqueo



○ Pulsación suave ● Pulsação suave



○ Tiempo ajustable ● Tempo ajustável

● Pressione normal ◎ Pression normale

● Antibloccaggio ◎ Anti-verrouillage

● Pressione morbida ◎ Douce push

● Tempo regolabile ◎ Temps réglable

111



○ Grifería temporizada

● Torneiras temporizada

● Rubinetteria temporizzata

⊙ Robinet temporisé



07690.LN Essentialtemp

NEW • NUEVO • NUOVO • NOUVEAU



○ Grifo temporizado mural para ducha, instalación vista

● Torneira temporizada uma água para chuveiro, instalação exposta

● Rubinetto temporizzato a parete per doccia, installazione a vista

⊙ Robinet temporisé mural pour douche, installation visible

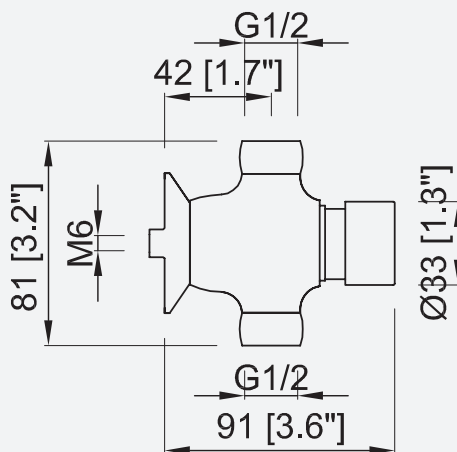

	6 l/min	07690.LN 51,80 €	07690.LA 66,80 €	07690.LS 68,80 €	07690.LR 98,00 €
		97001.25.N 29,60 €	97001.25.A 32,90 €	97004.DS 46,00 €	97004.DR 60,00 €



07670.LN Essentialtemp

NEW • NUEVO • NUOVO • NOUVEAU



○ Grifo temporizado un agua para ducha, instalación empotrada

● Torneira temporizada uma água para chuveiro, instalação nivelada

● Rubinetto temporizzato per la doccia, installazione ad incasso

⊙ Robinet temporisé à une eau pour douche, installation encastrée

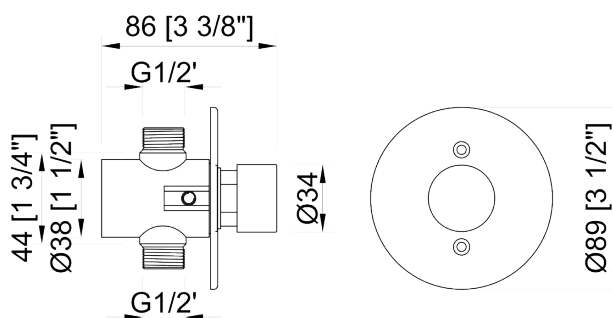

	6 l/min	07670.LN 44,90 €	07670.LA 59,90 €	07670.LS 61,90 €	07670.LR 99,00 €
		07670.N 43,90 €	07670.A 58,90 €	07670.S 60,90 €	07670.R 98,00 €
	97001.25.N 29,60 €	97001.25.A 32,90 €	97004.DS 46,00 €	97004.DR 60,00 €	



○ Pulsación normal ● Pulsação normal



○ Antiblocaje ● Anti-bloqueo



○ Pulsación suave ● Pulsação suave



○ Tempo ajustable ● Tempo ajustável

● Pressione normal ○ Pression normale

● Antibloccaggio ○ Anti-verrouillage

● Pressione morbida ○ Douce push

● Tempo regolabile

● Temps réglable



Mezclador

Cuerpo de latón CW617N cromado. Componentes plásticos en POM

Tiempo de actuación
20 ± 5 s

Filtro antipartículas

Temperatura máxima 85° C.
Temperatura máxima recomendada 60° C

Presión de trabajo entre 6-0,5 bar. Presión recomendada 3 bar



Misturador

Corpo em latão cromado CW617N. Componentes plásticos em POM

Tempo de atuação 20 ± 5 s

Filtro anti-particulado

Temperatura máxima 85 °C.
Temperatura máxima recomendada 60 ° C

Pressão de trabalho entre 6-0,5 bar. Pressão recomendada 3 bar



Miscelatore

Corpo in ottone CW617N cromato. Componenti in plastica in POM

Tempo di attivazione
20 ± 5 s

Filtro antiparticolato

Temperatura massima 85° C.
Temperatura massima consigliata 60° C

Pressione di esercizio tra 6-0,5 bar. Pressione consigliata 3 bar



Mitigeur

Corps en laiton CW617N chromé. Composant plastiques en POM

Durée de fonctionnement
20 ± 5 s

Filtre antiparticules

Température maximale 85 °C.
Température maximale recommandée 60° C

Pression de fonctionnement entre 6-0,5 bar. Pression recommandée 3 bar



- Grifería temporizada
- Torneiras temporizada
- Rubinetteria temporizzata
- Robinet temporisé



07670M.LB

Luxtemp

NEW • NUEVO • NOUVEAU



- Grifo mezclador temporizado de ducha
- Torneira misturadora temporizada para duche
- Miscelatore temporizzato per doccia
- Mitigeur temporisé de douche

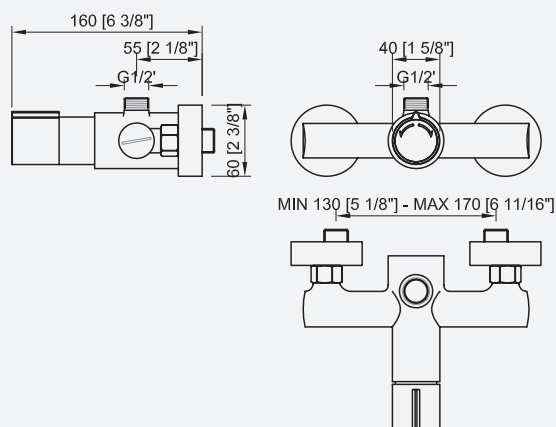

6 l/min	07670M.LB 226,00 €
9 l/min	07670M.B 225,00 €
	97440.30.S 30,00 €



97441 30,00 €
o ver pág. 121
• ver pág. 121
• v. pag. 121
o voir p. 121



07670M.LBG

Luxtemp

NEW • NUEVO • NOUVEAU

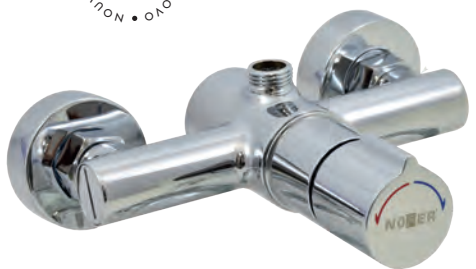

- Grifo mezclador temporizado de ducha con válvula antilegionella
- Torneira misturadora temporizada para duche com válvula antilegionella
- Miscelatore temporizzato per doccia con valvola antilegionella
- Mitigeur temporisé de douche avec valve antilégionelle

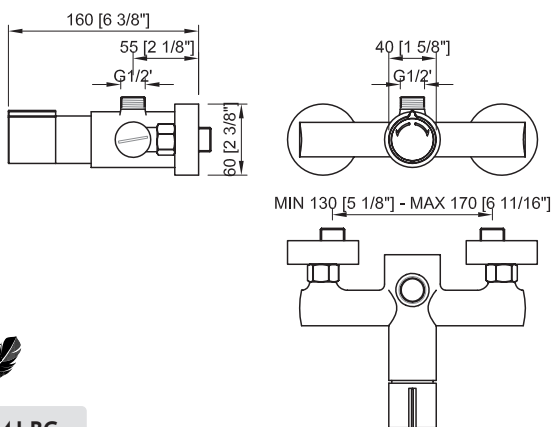

6 l/min	07670M.LBG 236,00 €
9 l/min	07670M.BG 235,00 €
	97440.30.S 30,00 €



97441 30,00 €
o ver pág. 121
• ver pág. 121
• v. pag. 121
o voir p. 121



- Pulsación suave
- Pulsação suave
- Pressione morbida
- Douce push



07662.LB 07662.LBG

Luxtemp

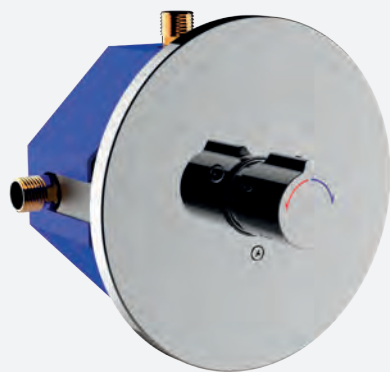

- Grifo mezclador temporizado para ducha. Instalación empotrada con caja y 3 racores de conexión. Versión con sistema antilegionella 07662.LBG
- Miscelatore doccia temporizzato. Installazione ad incasso con cassa e 3 raccordi di connessione. Versione con sistema antilegionella 07662.LBG

- Misturador monocomando para chuveiro. Instalação embutida com caixa e 3 conexões de encaixe. Versão com sistema antilegionella 07662.LBG
- ◎ Mitigeur de douche temporisé. Installation encastrée avec boîtier et 3 raccords de connexion. Version avec système antilegionelle 07662.LBG

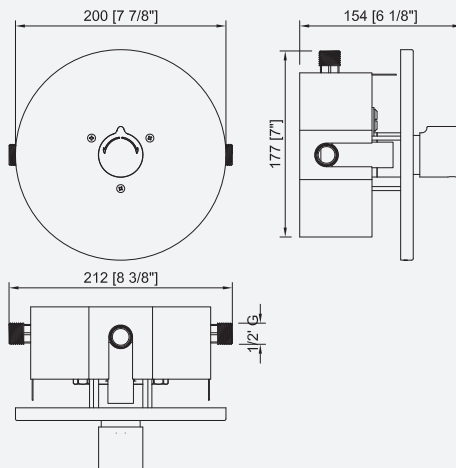

6 l/min	07662.LB 275,50 €	07662.LBG 285,50 €
9 l/min	07662.B 274,50 €	07662.BG 284,50 €
	97440.30.S 30,00 €	97440.30.S 30,00 €



07663.LB 07663.LBG

Luxtemp

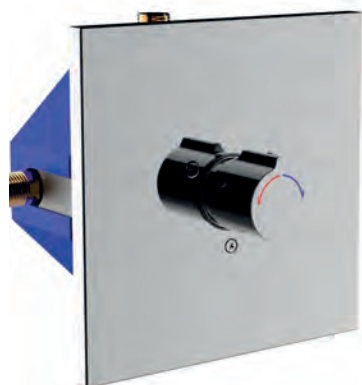

- Grifo mezclador temporizado para ducha. Instalación empotrada con caja y 3 racores de conexión. Versión con sistema antilegionella 07663.LBG
- Miscelatore doccia temporizzato. Installazione ad incasso con cassa e 3 raccordi di connessione. Versione con sistema antilegionella 07663.LBG

- Misturador monocomando para chuveiro. Instalação embutida com caixa e 3 conexões de encaixe. Versão com sistema antilegionella 07663.LBG
- ◎ Mitigeur de douche temporisé. Installation encastrée avec boîtier et 3 raccords de connexion. Version avec système antilegionelle 07663.LBG

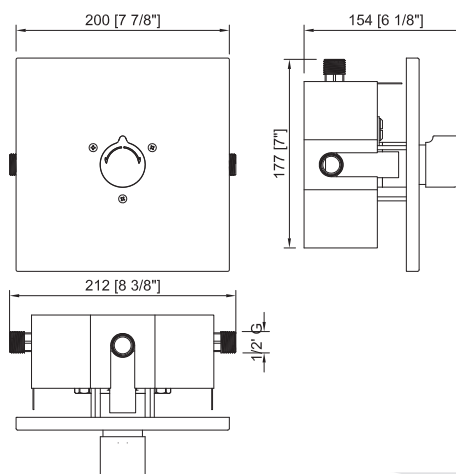

6 l/min	07663.LB 280,50 €	07663.LBG 290,50 €
9 l/min	07663.B 279,50 €	07663.BG 289,50 €
	97440.30.S 30,00 €	97440.30.S 30,00 €



○ Grifería temporizada

● Torneiras temporizada

● Rubinetteria temporizzata

⊙ Robinet temporeisé

Conjuntos de ducha

Cuerpo de latón CW617N cromado bajo la norma EN 248. Componentes plásticos en POM

Tiempo de actuación 20 ± 5 s

Filtro antipartículas

Temperatura máxima 85°C. Temperatura máxima recomendada 60° C

Presión de trabajo entre 0,5-6 bar. Presión recomendada 3 bar

Conjuntos de chuveiro

Corpo de latão CW617N, cromado de acordo com a norma EN 248. Componentes de plástico POM

Tempo de atuação 20 ± 5 s

Filtro anti-particulado

Temperatura máxima 85° C. Temperatura máxima recomendada 60° C

Pressão de trabalho entre 0,5-6 bar. Pressão recomendada 3 bar

Set doccia

Corpo in ottone cromato CW617N secondo EN 248. Componenti in plastica in POM

Tempo di attivazione 20 ± 5 s

Filtro antiparticolato

Temperatura massima 85° C. Temperatura massima consigliata 60° C

Pressione di esercizio tra 0,5-6 bar. Pressione consigliata 3 bar

Ensembles de douche

Corps en laiton CW617N chromé selon la norme EN 248. Composants plastiques en POM

Durée de fonctionnement 20 ± 5 s

Filtre antiparticules

Température maximale 85 °C. Température maximale recommandée 60° C

Pression de fonctionnement entre 0,5-6 bar. Pression recommandée 3 bars



07610C.LN Essentialtemp

○ Conjunto de ducha un agua. Instalación vista

● Conjunto de chuveiro, instalação exposta

● Set doccia installazione a vista

⊙ Ensemble de douche à une eau. Installation visible

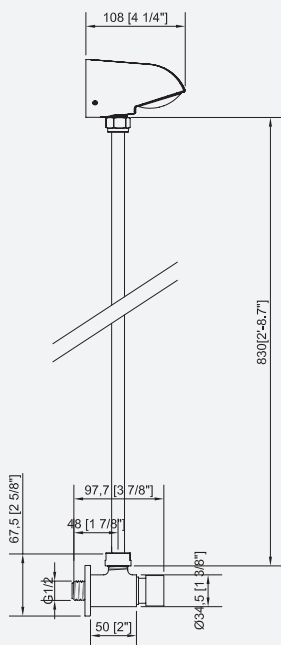
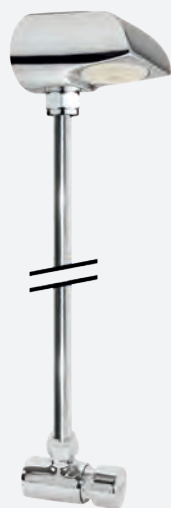

6 l/min	07610C.LN	07610C.LA	07610C.LS	07610C.LR
	164,00 €	179,00 €	181,00 €	254,00 €
	97001.25.N	97001.25.A	97004.DS	97004.DR
	29,60 €	32,90 €	46,00 €	60,00 €



○ Pulsación normal ● Pulsação normal



○ Antiblocaje ● Anti-bloqueio



○ Pulsación suave ● Pulsação suave



○ Tiempo ajustable ● Tempo ajustável

● Pressione normal ⊙ Pression normale

● Antibloccaggio ⊙ Anti-verrouillage

● Pressione morbida ⊙ Douce push

● Tempo regolabile

⊙ Temps réglable



07690C.LN Essentialtemp

- Conjunto de ducha un agua. Instalación vista
- Conjunto de chuveiro, instalação exposta
- Set doccia installazione a vista
- Ensemble de douche à une eau. Installation visible

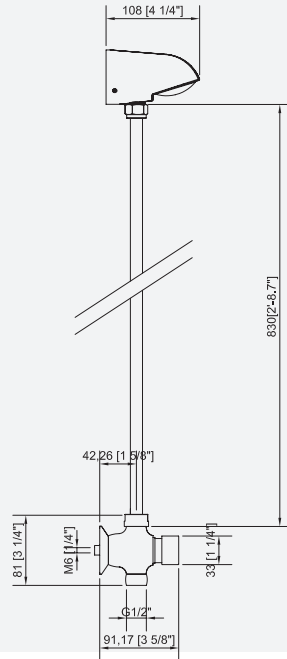

6 l/min	07690C.LN	07690C.LA	07690C.LS	07690C.LR
	169,00 €	184,00 €	186,00 €	198,00 €
97001.25.N	97001.25.A	97004.DS	97004.DR	
	29,60 €	32,90 €	46,00 €	60,00 €



07670MC.LS Luxtemp

- Conjunto de ducha con pulsador temporizado mezclador
- Conjunto de chuveiro com botão temporizado misturador.
- Set doccia con pulsante temporizzato miscelatore
- Ensemble de douche avec bouton poussoir mitigeur temporisé

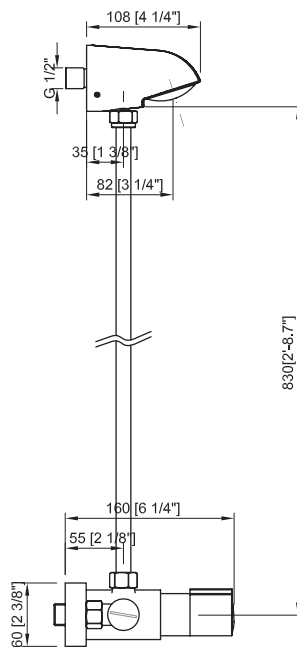

6 l/min	07670MC.LS
	350,00 €
9 l/min	07670MC.S
	349,00 €
97440.30.S	
	30,00 €



○ Pulsación normal ● Pulsação normal



○ Antiblocaje ● Anti-bloqueo



○ Pulsación suave ● Pulsação suave



○ Tiempo ajustable ● Tempo ajustável



Grifería temporizada

Torneiras temporizada

Rubinetteria temporizzata

Robinet temporisé



07670MC.LSG

Luxtemp

Conjunto de ducha con pulsador temporizado mezclador. Con sistema antilegionella

Conjunto de chuveiro com botão temporizado misturador. Com sistema antilegionella

Set doccia con pulsante temporizzato miscelatore. Con sistema antilegionella

Ensemble de douche avec bouton poussoir mitigeur temporisé. Avec système antilegionelle

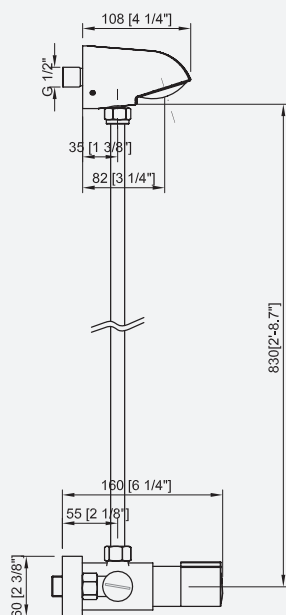
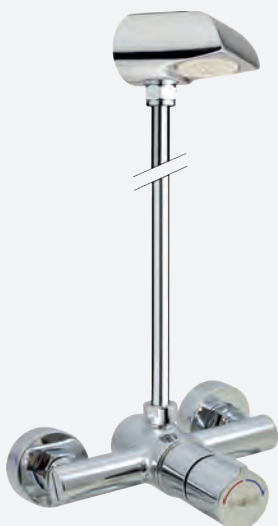

	07670MC.LSG 360,00 €
	07670MC.SG 359,00 €
	97440.30.S 30,00 €

07067.B

Conjunto tubo y rociador de ducha

Conjunto tubo e rociador de ducha

Set doccia con tubo e soffione

Ensemble pomme de douche et tube

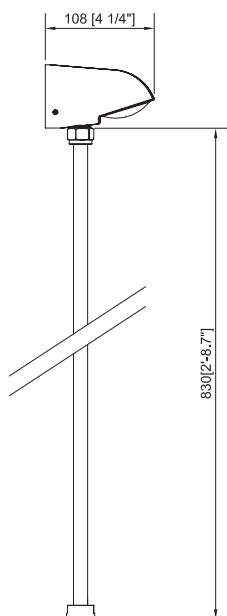

	07067.B 125,00 €
--	----------------------------



Pulsación suave Pulsação suave
 Pressione morbida Douce push

○
Rociadores

Cuerpo de latón cromado

●
**Cabeças de
chuveiro**

Corpo em latão cromado

●
Soffioni

Corpo in ottone cromato

◎
**Pommes de
douche**

Corps en laiton chromé

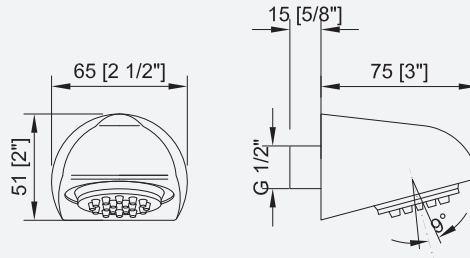
07070.B

○ Rociador fijo para ducha con difusor orientable

● Soffione fisso doccia con diffusore orientabile

● Cabeça de chuveiro fixa com difusor ajustável

◎ Pomme de douche fixe avec diffuseur réglable

9 l/min **07070.B**
155,00 €

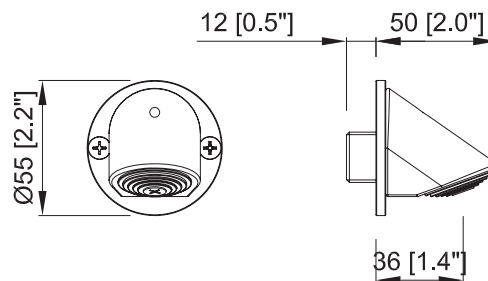
6 l/min **07070.LB**
156,00 €
07071.B

○ Rociador antivandálico fijo para ducha. Con tornillería de seguridad Torx

● Soffione fisso antivandalo. Con viti di sicurezza Torx

● Cabeça de chuveiro fixo anti-vandalismo. Com parafusos de segurança Torx

◎ Pomme de douche fixe anti-vandalisme. Avec vis de sécurité Torx

9 l/min **07071.B**
35,00 €

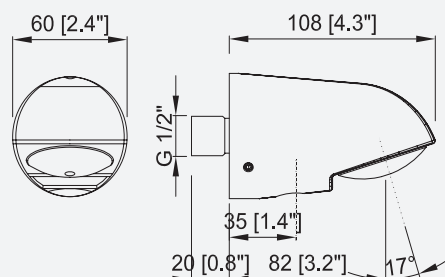
6 l/min **07071.LB**
36,00 €
07072.B

○ Rociador fijo para ducha con posibilidad de alimentación vista

● Soffione fisso con possibilità di alimentazione in superficie

● Cabeça de chuveiro fixa com possibilidade de alimentação vista

◎ Pomme de douche fixe avec possibilité d'alimentation visible

9 l/min **07072.B**
75,90 €

6 l/min **07072.LB**
76,90 €



○ Grifería temporizada

● Torneiras temporizada

● Rubinetteria temporizzata

⊙ Robinet temporisé

07074.2.B

○ Rociador de ducha mural orientable

● Chuveiro de parede orientável

● Soffione doccia a parete orientabile

⊙ Pomme de douche orientable mural

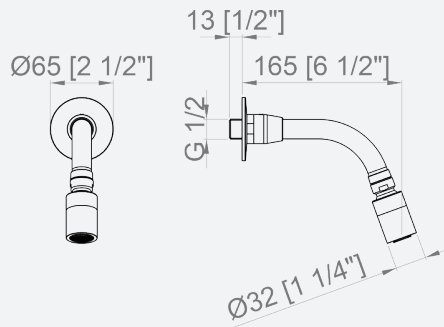

9 l/min **07074.2.B**
95,00 €

6 l/min **07074.2.LB**
96,00 €

07073.B

○ Rociador orientable para ducha

● Chuveiro orientável para banho

● Soffione orientabile per doccia

⊙ Pommeau de douche orientable

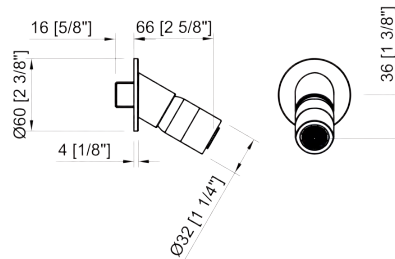

9 l/min **07073.B**
85,00 €

6 l/min **07073.LB**
86,00 €

07075.B

○ Rociador fijo para ducha

● Cabeça de chuveiro fixa

● Soffione fisso per doccia

⊙ Pomme de douche fixe

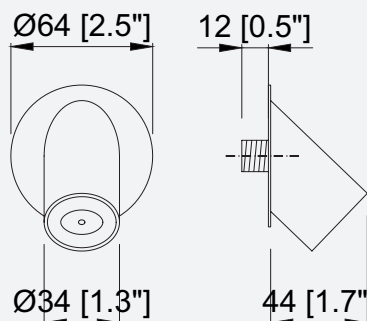

9 l/min **07075.B**
35,50 €

6 l/min **07075.LB**
36,50 €



○
Accesorios de ducha

Cuerpo de latón CW617N cromado bajo la norma EN 248

●
Acessórios de banho

Fabricado em latão cromado

●
Accessori doccia

Fabbricati in ottone cromato

⊙
Accessoires de douche

Fabriqu  en laiton chrom 

97441



○ Racor de conversi n instalaci n vista a empotrada para grifo 07670M

● Racor de convers o instala o encastrada para torneira 07670M

● Raccordo di conversione installazione a vista / installazione ad incasso per rubinetto 07670M

⊙ Raccord de conversion d'installation visible   encastr e pour robinet 07670M

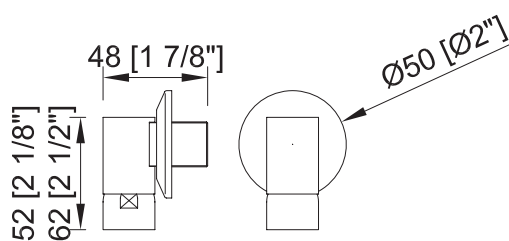

97441
30,00  

97009.G



○ V lvula antilegionella 1/2" G

● V lvula antilegionella 1/2" G

● V lvula antilegionella 1/2" G

⊙ Valve antilegionelle 1/2" G

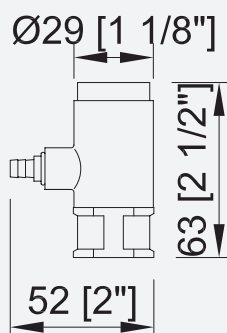

97009.G
40,00  



Grifería temporizada

Torneiras temporizada

Rubinetteria temporizzata

Robinet temporisé



Columnas de ducha

Cuerpo de acero inoxidable AISI 304 acabado brillo.
Rociador de ABS

Activación mediante botón pulsador temporizado



Colunas de chuveiro

Corpo em aço inox AISI 304 com acabamento brilhante.
Pulverizador ABS

Ativação por botão cronometrado



Colonne doccia

Corpo in acciaio inox AISI 304 finitura lucida.
Soffione ABS

Attivazione tramite pulsante temporizzato



Panneaux de douche

Corps en acier inoxydable AISI 304 finition brillant.
Pomme de douche en ABS

Déclenchement par bouton-poussoir temporisé



13414.B



- Columna de ducha de acero inoxidable con un rociador y un pulsador temporizado
- Colonna doccia in acciaio inossidabile con soffione e pulsante temporizzati

- Torre de chuveiro de aço inoxidável com um rociador e um pulsador temporizado
- ◎ Panneau de douche en acier inoxydable avec une pomme de douche et un bouton poussoir temporisé

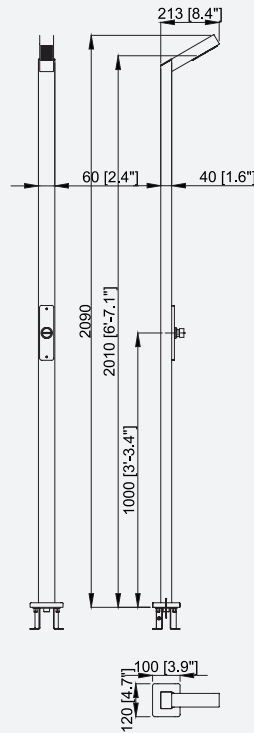

13414.B
885,00 €

13415.B



- Columna de ducha de acero inoxidable con un rociador, un lavapies y dos pulsadores temporizados
- Colonna doccia in acciaio inossidabile con soffione, rubinetto per lavare i piedi e due pulsanti temporizzati

- Torre de chuveiro de aço inoxidável com um rociador, uma lavadora de pés e dois pulsadores temporizados
- ◎ Panneau de douche en acier inoxydable avec une pomme de douche, un lave-pieds et deux boutons poussoirs temporisés

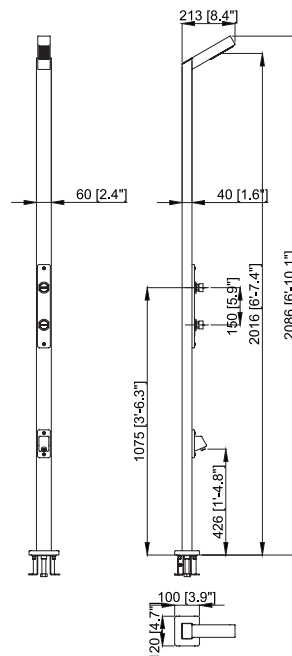

13415.B
1.150,00 €



○ Pulsación normal

● Pulsação normal

● Pressione normal

◎ Pression normale



○ Grifería temporizada

● Torneiras temporizada

● Rubinetteria temporizzata

⊙ Robinet temporisé

13416.B

○ Columna de ducha de acero inoxidable con dos rociadores y dos pulsadores temporizados

● Colonna doccia in acciaio inossidabile con due soffioni e due pulsanti temporizzati

● Torre de chuveiro de aço inoxidável com dois rociadores e dois pulsadores temporizados

⊙ Panneau de douche en acier inoxydable avec deux pommes de douche et deux boutons poussoirs temporisés

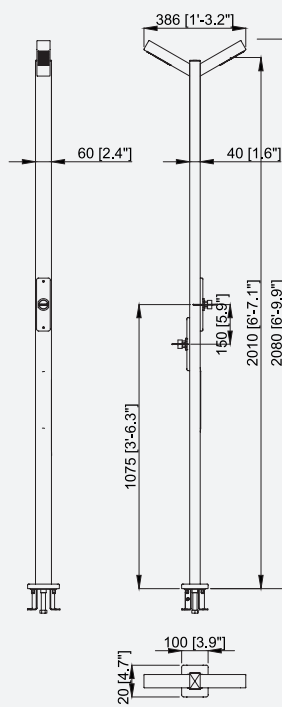

13416.B
1.850,00 €

13417.B

○ Columna de ducha de acero inoxidable con cuatro rociadores y cuatro pulsadores temporizados

● Colonna doccia in acciaio inossidabile con quattro soffioni e quattro pulsanti temporizzati

● Torre de chuveiro de aço inoxidável com quatro rociadores e quatro pulsadores temporizados

⊙ Panneau de douche en acier inoxydable avec quatre pommes de douche et quatre boutons poussoirs temporisés

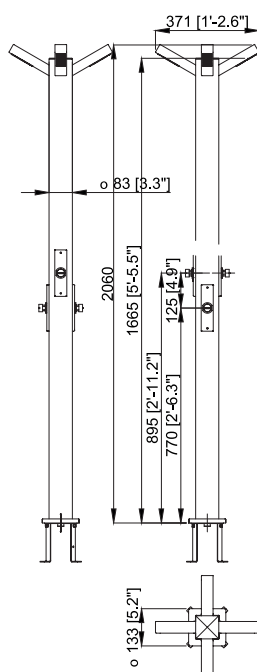

13417.B
2.260,00 €



○ Pulsación normal ● Pulsação normal
● Pressione normal ⊙ Pression normale



13420.B

○ Columna de ducha de acero inoxidable con un rociador y un pulsador temporizado

● Torre de chuveiro de aço inoxidável com um rociador e um pulsador temporizado

● Colonna doccia in acciaio inossidabile con un soffione e un pulsante temporizzato

⊙ Panneau de douche en acier inoxydable avec une pomme de douche et un bouton poussoir temporisé

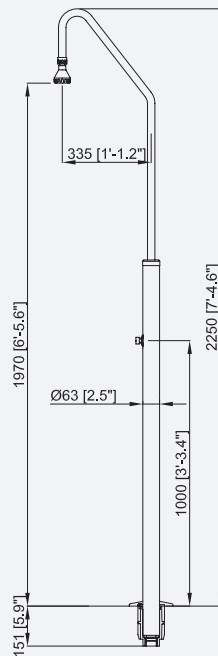

13420.B
780,00 €

13418.B

○ Columna de ducha de acero inoxidable con un rociador y un grifo de rosca

● Torre de chuveiro de aço inoxidável com um rociador e uma torneira

● Colonna doccia in acciaio inossidabile con soffione e rubinetto con maniglia

⊙ Panneau de douche en acier inoxydable avec une pomme de douche et un robinet fileté

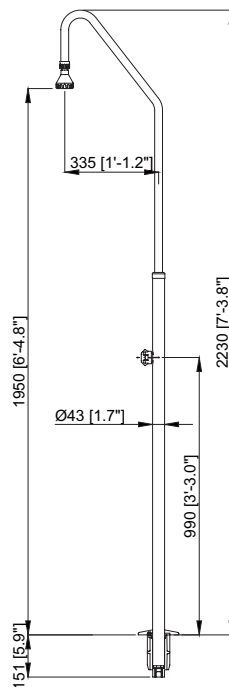

13418.B
375,00 €



○ Pulsación normal

● Pulsação normal

● Pressione normal

⊙ Pression normale



○ Grifería temporizada

● Torneiras temporizada

● Rubinetteria temporizzata

⊙ Robinet temporisé

13419.B

○ Columna de ducha de acero inoxidable con un rociador, lavapiés y un grifo de rosca

● Colonna doccia in acciaio inossidabile con soffione, rubinetto per lavare i piedi e rubinetto con maniglia

● Torre de chuveiro de aço inoxidável com um rociador, lavadora de pés e uma torneira

⊙ Panneau de douche en acier inoxydable avec une pomme de douche, lave-pieds et un robinet fileté

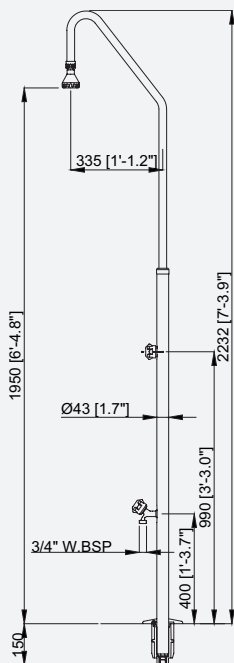

13419.B
405,00 €

13422.B

○ Columna de ducha solar con un rociador y un grifo monomando

● Colonna doccia solare con soffione e miscelatore monocomando

● Torre de chuveiro solar com um rociador e uma torneira misturadora

⊙ Panneau de douche solaire avec une pomme de douche et un mitigeur

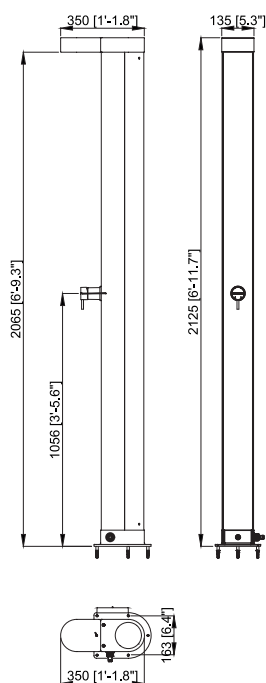

13422.B
1.125,00 €



○ Pulsación normal ● Pulsação normal

● Pressione normal ⊙ Pression normale





Grifería temporizada

Torneiras temporizada

Rubinetteria temporizzata

Robinet temporisé



Fregadero

Cuerpo de latón CW617N cromado. Componentes plásticos en POM

Tiempo de actuación 7 ± 3 s. Tiempo de actuación modelo 07470M.B 15 ± 5 s

Filtro antipartículas

Temperatura máxima 85°C. Temperatura máxima recomendada 60° C

Presión de trabajo entre 0,5-6 bar. Presión recomendada 3 bar



Fregadero

Corpo em latão cromado CW617N. Componentes plásticos em POM

Tempo de atuação 7 ± 3 s. Tempo de atuação modelo 07470M.B 15 ± 5 s

Filtro anti-particulado

Temperatura máxima 85° C. Temperatura máxima recomendada 60° C

Pressão de trabalho entre 0,5-6 bar. Pressão recomendada 3 bar



Lavello

Corpo in ottone CW617N cromato. Componenti in plastica in POM

Tempo di prestazione 7 ± 3 s. Tempo di prestazione modello 07470M.B 15 ± 5 s

Filtro antiparticolato

Temperatura massima 85° C. Temperatura massima consigliata 60° C

Pressione di esercizio tra 0,5-6 bar. Pressione consigliata 3 bar



Évier

Corps en laiton CW617N chromé. Composant plastiques en POM

Durée de fonctionnement 7 ± 3 s. Durée de fonctionnement modèle 07470M.B 15 ± 5 s

Filtre antiparticules

Température maximale 85 °C. Température maximale recommandée 60° C

Pression de fonctionnement entre 0,5-6 bar. Pression recommandée 3 bars



07510.N

Essentialtemp

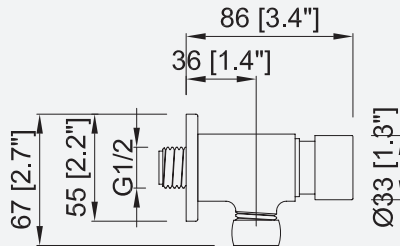

○ Grifo temporizado mural para fregadero. Instalación vista. Conexión inferior o superior

● Rubinetto lavabo a parete temporizzato. Installazione visibile. Connessione inferiore o superiore

● Torneira para pia com temporizador de parede. Instalação visível. Conexão inferior ou superior

⊙ Robinet d'évier mural temporisé. Installation visible. Connexion inférieure ou supérieure



	6 l/min	07510.N 32,00 €	07510.A 47,00 €	07510.S 49,00 €	07510.R 75,00 €
		97001.07.N 21,20 €	97001.07.A 24,50 €	97004.US 42,60 €	97004.LR 50,00 €

07490.N

Essentialtemp

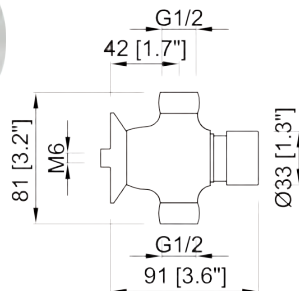

○ Grifo temporizado mural para fregadero. Instalación vista. Conexión inferior y superior

● Rubinetto lavabo a parete temporizzato. Installazione visibile. Connessione inferiore e superiore

● Torneira para pia com temporizador de parede. Instalação visível. Conexão inferior e superior

⊙ Robinet d'évier mural temporisé. Installation visible. Connexion inférieure et supérieure



	6 l/min	07490.N 41,70 €	07490.A 56,70 €	07490.S 58,70 €	07490.R 87,30 €
		97001.07.N 21,20 €	97001.07.A 24,50 €	97004.US 42,60 €	97004.LR 50,00 €

07510P.S

Essentialtemp

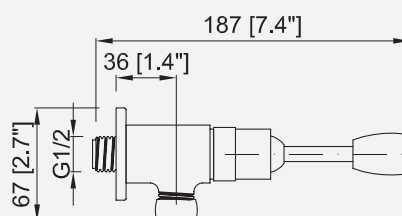

○ Grifo mural temporizado un agua salida inferior, activado por palanca. Conexión inferior y superior

● Rubinetto a parete temporizzato, comando a leva. Connessione inferiore e superiore

● Torneira de parede temporizada saída inferior, ativada por alavanca. Conexão inferior e superior

⊙ Robinet mural temporisé à une eau, fonctionne avec levier. Connexion inférieure et supérieure



6 l/min	07510P.S 60,00 €
	97001.P 42,50 €



○ Pulsación normal ● Pulsação normal



○ Antiblocaje ● Anti-bloqueo



○ Pulsación suave ● Pulsação suave



○ Tiempo ajustable ● Tempo ajustável

● Pressione normal ⊙ Pression normale

● Antibloccaggio ⊙ Anti-verrouillage

● Pressione morbida ⊙ Douce push

● Tempo regolabile

⊙ Temps réglable



○ Grifería temporizada

● Torneiras temporizada

● Rubinetteria temporizzata

⊙ Robinet temporisé

07490P.S Essentialtemp



○ Grifo mural temporizado un agua, activado por palanca. Conexión inferior y superior

● Rubinetto a parete temporizzato, comando a leva. Connessione inferiore e superiore

● Torneira de parede temporizada ativada por alavanca. Conexão inferior e superior

⊙ Robinet mural temporisé à une eau, fonctionne avec levier. Connexion inférieure et supérieure

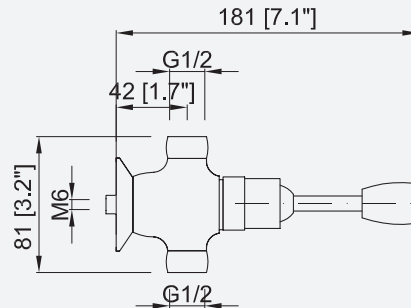

6 l/min

07490P.S
75,00 €

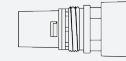

97001.P
42,50 €

○ Mezcladores ● Misturadoras ● Miscelatore ⊙ Mitigeurs

07470M.B Luxtemp



NEW • NUEVO • NOUVEAU

○ Grifo mezclador temporizado para fregadero. Tiempo de actuación 15 ± 5 s. Conexión superior

● Miscelatore temporizzato per lavello. Connessione superiore

● Torneira misturadora temporizada para pia. Conexão superior

⊙ Mitigeur temporisé pour évier. Connexion supérieure

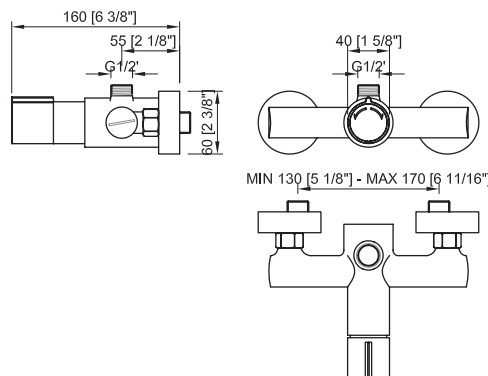

6 l/min

07470M.B
225,00 €

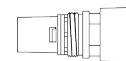

97440.15.S
30,00 €

○ Caños ● Canos ● Bocchelli ⊙ Becs

07012.2.B



○ Caño extensible y giratorio de latón cromado para fregadero

● Bocchello girevole telescopico in ottone per lavello cromato

● Bica extensível e giratória de latão cromado para pia

⊙ Bec verseur extensible et pivotant en laiton chromé pour évier

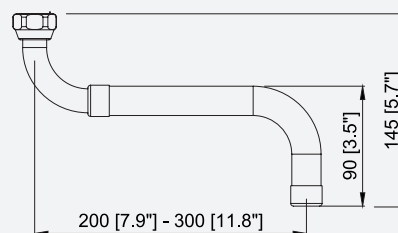

07012.2.B
30,00 €



○ Grifería temporizada

● Torneiras temporizada

● Rubinetteria temporizzata

⊙ Robinet temporisé



○ Caños

● Canos

● Bocchelli

⊙ Becs

07018.2.B



○ Caño giratorio de latón cromado para fregadero

● Bocchello girevole in ottone per lavello cromato

● Bica giratória de latão cromado para pia

⊙ Bec verseur pivotant en laiton chromé pour évier

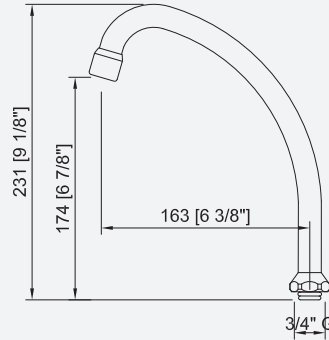

07018.2.B
15,00 €

07104.B



○ Caño de latón cromado para fregadero

● Bocchello in ottone cromato per lavello

● Cano de latão cromado para pia

⊙ Bec d'évier en laiton chromé

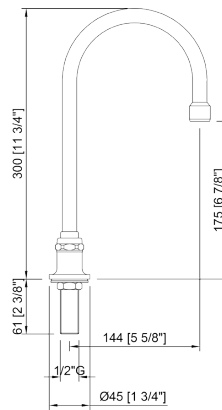

07104.B
55,00 €

07013.2.B



○ Caño giratorio de latón cromado para fregadero

● Bocchello in ottone cromato per lavello

● Cano de latão cromado para pia

⊙ Bec verseur pivotant en laiton chromé pour évier

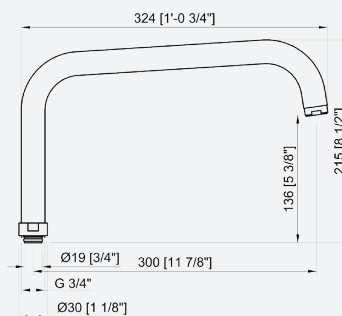

07013.2.B
36,50 €



○ Grifería temporizada

● Torneiras temporizada

● Rubinetteria temporizzata

⊙ Robinet temporisé

97195



○ Racor de conexión para caño fregadero mural

● Raccordo di connessione per bocchello a parete per lavello

● Conector de conexión para torneira de parede de pia

⊙ Raccord de connexion pour bec d'évier mural

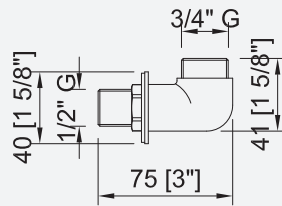

97195
20,00 €

97193



○ Racor de conexión para caño fregadero sobre encimera

● Raccordo di connessione per bocchello per lavello sopra piano

● Conector de conexión para torneira de pia de bancada

⊙ Raccord de connexion pour bec d'évier sur plan de travail

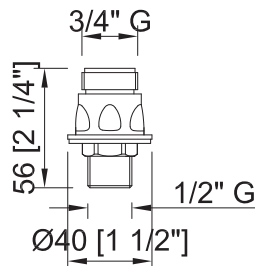

97193
20,00 €

97129



○ Racor de unión grifo fregadero/caño

● Raccordo di unione lavello / bocchello

● Racor de unión torneira pia / cano

⊙ Raccord union robinet évier / bec

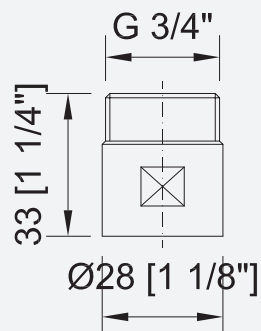

97129
16,50 €



07012C.B



- Conjunto de caño y racor de unión
- Gruppo per bocchello e raccordo di connessione

- Conjunto de bica e conector de união
- Ensemble de bec et raccord-union

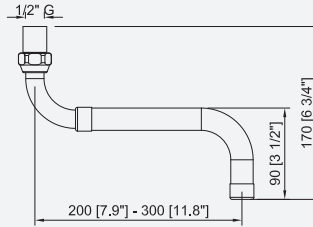

07012C.B
45,00 €

07018C.B

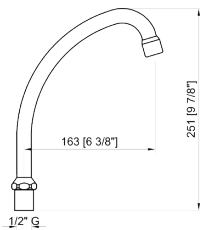

- Conjunto de caño y racor de unión
- Conjunto de bica e conector de união
- Gruppo per bocchello e raccordo di connessione
- Ensemble de bec et raccord-union

07018C.B
30,00 €

07018C3.B

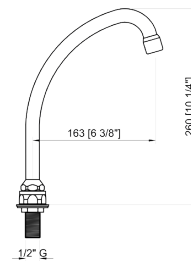

- Conjunto de caño y racor de unión
- Conjunto de bica e conector de união
- Gruppo per bocchello e raccordo di connessione
- Ensemble de bec et raccord-union

07018C3.B
30,00 €

07013C.B



- Conjunto de caño y racor de unión
- Gruppo per bocchello e raccordo di connessione

- Conjunto de bica e conector de união
- Ensemble de bec et raccord-union

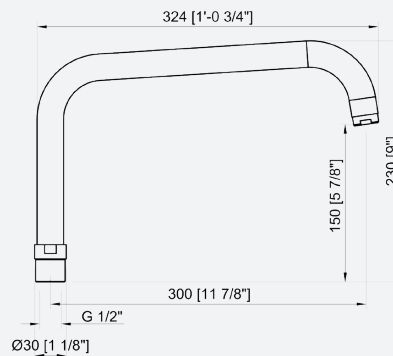

07013C.B
52,00 €













○ Grifería temporizada

● Torneiras temporizada

● Rubinetteria temporizzata

◎ Robinet temporisé

		07012C.B		07018C.B	07013C.B
					
07510.N		<input checked="" type="checkbox"/>			
			<input checked="" type="checkbox"/>	<input checked="" type="checkbox"/>	<input checked="" type="checkbox"/>
07490.N		<input checked="" type="checkbox"/>	<input checked="" type="checkbox"/>	<input checked="" type="checkbox"/>	<input checked="" type="checkbox"/>
07510PS		<input checked="" type="checkbox"/>			
			<input checked="" type="checkbox"/>	<input checked="" type="checkbox"/>	<input checked="" type="checkbox"/>
07490PS		<input checked="" type="checkbox"/>	<input checked="" type="checkbox"/>	<input checked="" type="checkbox"/>	<input checked="" type="checkbox"/>
07470M.B			<input checked="" type="checkbox"/>	<input checked="" type="checkbox"/>	<input checked="" type="checkbox"/>



- **GRIFERÍA
DE PEDAL**
- **TORNEIRAS
A PEDAL**
- **RUBINETTI
A PEDALE**
- ⦿ **ROBINET
À PEDALE**



○ GRIFERÍA
DE PEDAL

● RUBINETTI
A PEDALE

● TORNEIRAS
DE PEDAL

◎ ROBINETS
À PÉDALE

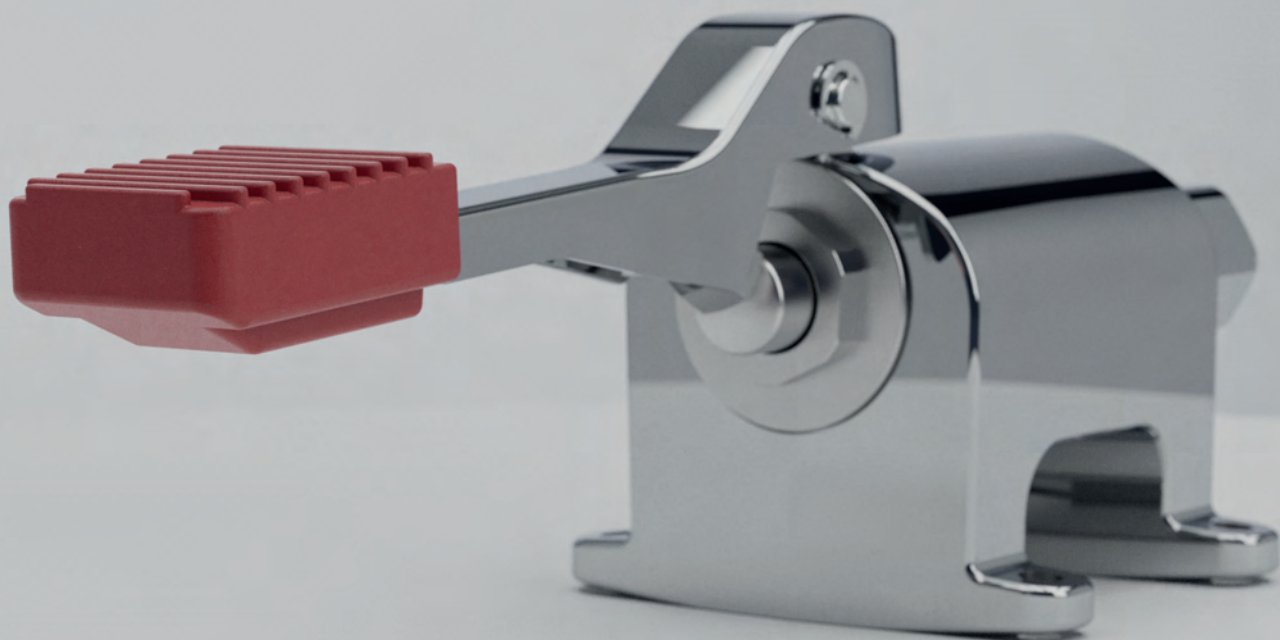



Un agua

Cuerpo de latón CW617N cromado bajo la norma EN 248



Um água

Corpo de latão CW617N, cromado sob a norma EN 248



Monocomando

Corpo in ottone cromato CW617N sotto lo standard EN 248



Une eau

Corps en laiton CW617N chromé selon la norme EN 248

07106.2.B



○ Grifo monopedal un agua fijación a suelo

● Rubinetto monopedale a pavimento

● Torneira um pedal no chão de uma água

⦿ Robinet monopédale à une eau, fixation au sol

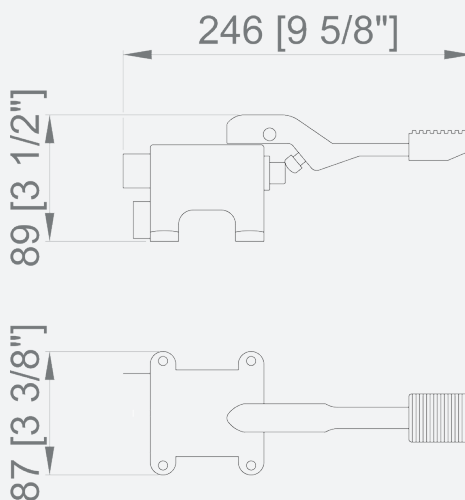

07106.2.B
98,00 €



○ Grifería De pedal

● Torneiras A pedal

● Rubinetti A pedale

⊙ Robinet À pedale

07112.2.B

○ Grifo pulsador de pie un agua empotrado fijación a suelo

● Torneira botão de pé embutido no chão de uma água

● Rubinetto a pulsante a pavimento

⊙ Robinet poussoir à une eau, à commande au pied, encastré au sol

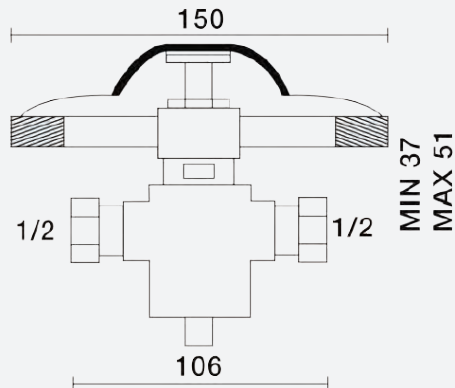

07112.2.B
190,00 €

07465.N

○ Grifo pulsador para instalación en panel chapa

● Torneira de botão para instalação em painel chapa

● Rubinetto a pulsante per installazione pannello di lamiera

⊙ Robinet à bouton poussoir pour installation sur panneau d'acier



07465.N
33,50 €



Mezclador

Cuerpo de latón CW617N cromado bajo la norma EN 248



Misturadores

Corpo de latão CW617N, cromado sob a norma EN 248



Miscelatori

Corpo in ottone cromato CW617N sotto lo standard EN 248



Mitigeurs

Corps en laiton CW617N chromé selon la norme EN 248

07107.2.B



○ Grifo monopedal mezclador progresivo fijación a suelo

● Miscelatore monopedale progressivo a pavimento

● Torneira um pedal no chão misturador progressivo

⊙ Robinet monopédale mitigeur progressif, fixation au sol

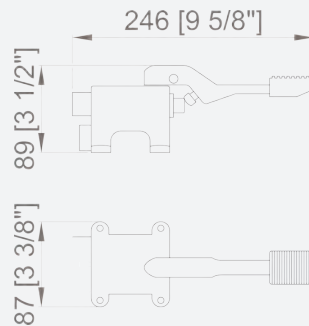

07107.2.B
140,00 €

07105.2.B

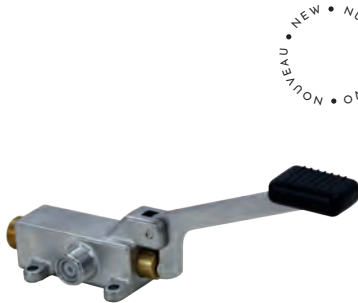

○ Grifo monopedal mezclador progresivo fijación a suelo

● Miscelatore monopedale progressivo a pavimento

● Torneira um pedal no chão misturador progressivo

⊙ Robinet monopédale mitigeur progressif, fixation au sol

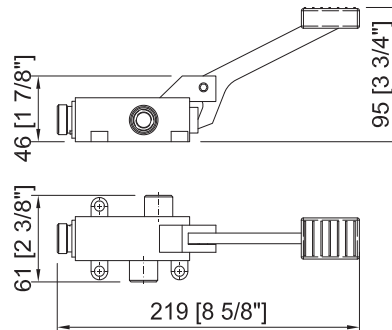

07105.2.B
77,00 €

07108.2.B



○ Grifo bipedal mezclador fijación a suelo

● Miscelatore a due pedali a pavimento

● Torneira pedal duplo misturador chão

⊙ Robinet mitigeur de deux pédales, fixation au sol

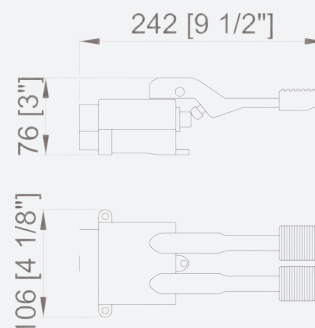

07108.2.B
160,00 €

- **GRIFERÍA
GERONTOLÓGICA**
- **TORNEIRAS
GERONTOLÓGICAS**
- **RUBINETTERIA
PER ANZIANI E DISABILI**
- ⊙ **ROBINETS
GÉRONTOLOGIQUES**



○ GRIFERÍA
GERONTOLÓGICA

● TORNEIRAS
GERONTOLÓGICAS

● RUBINETTI PER
ANZIANI E DISABILI

◎ ROBINETS
GÉRONTOLOGIQUES





○
Grifería gerontológica

Cuerpo de latón cromado

Activación por palanca monomando de gran longitudud

Caudal 10 l/min a 1 bar

●
Torneira gerontológica

Corpo em latão cromado

Ativação por alavanca longa de alavanca única

Fluxo de 10 l/min a 1 bar

●
Rubinetti per anziani e disabili

Corpo in ottone cromato

Attivazione tramite leva lunga monocomando

Portata 10 l/min a 1 bar

⊙
Robinet hospitalier

Corps en laiton chromé

Commande à levier long

Débit 10 l/min a 1 bar

07210.B



○ Grifo gerontológico monomando mezclador para lavabo encimera

● Miscelatore monocomando gerontologico sul bordo lavabo

● Torneira misturadora gerontológica monocomando para lavatorio

⊙ Miscelatore monocomando gerontologico sul piano lavabo

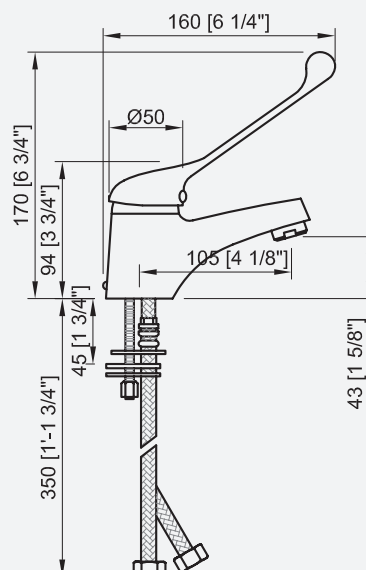

07210.B
47,50 €



○ Grifería gerontológica

● Torneira gerontológica

● Rubinettiper anziani e disabili

◎ Robinet hospitalier

07201.B



- Grifo gerontológico mural mezclador para lavabo
- Miscelatore gerontologico a parete per lavabo

- Misturador gerontológico de lavatório de parede
- ◎ Mitigeur mural gérontologique pour lavabo

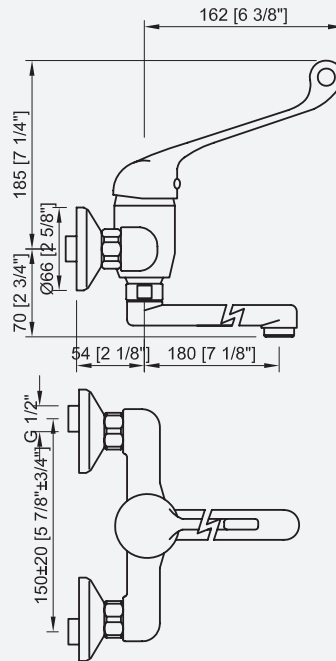

07201.B
76,70 €

07200.B



- Grifo gerontológico mezclador para lavabo sobre encimera
- Miscelatore gerontologico sul bordo lavabo

- Misturador gerontológico de lavatório de bancada
- ◎ Mitigeur gérontologique pour lavabo sur plan de travail

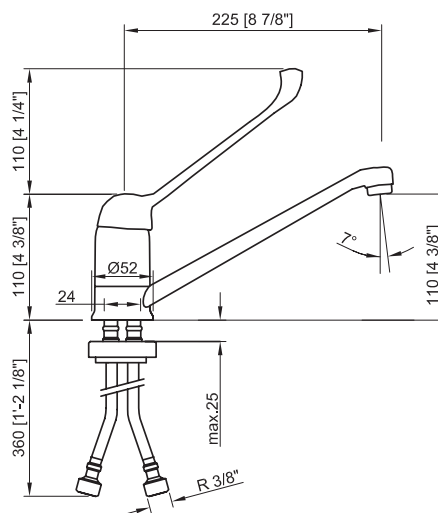

07200.B
52,90 €



- **GRIFERÍA
INDUSTRIAL**
- **TORNEIRA
INDUSTRIAL**
- **RUBINETTERIA
INDUSTRIALE**
- ⦿ **ROBINETS
INDUSTRIELS**



○ **GRIFERÍA
INDUSTRIAL**

● **RUBINETTI
INDUSTRIALI**

● **TORNEIRAS
PROFISSIONAIS**

◎ **ROBINETTERIE
INDUSTRIELLE**





○ Grifería industrial

Cuerpo de latón cromado

Adecuado para fregaderos de uso profesional

Caudal 17 l/min

Temperatura máxima 85° C.
Temperatura recomendada 65° C

● Torneira industrial

Corpo em latão cromado

Adequado para pias de uso profissional

Fluxo 17 l/min

Temperatura máxima 85° C.
Temperatura recomendada 65° C

● Rubinetteria industriale

Corpo in ottone cromato

Adatto per lavelli professionali

Portata 17 l/min

Temperatura massima 85° C.
Temperatura consigliata 65° C

◎ Robinet industriel

Corps en laiton chromé

Approprié pour les éviers à usage professionnel

Débit 17 l/min

Température maximale 85° C.
Température maximale recommandée 65° C

07101.2.B

○ Grifo de sobremesa tipo ducha un agua

● Torneira de área de trabalho tipo chuveiro de uma água

● Rubinetto soprapiano tipo doccia

◎ Robinet douchette sur plan de travail, à une eau

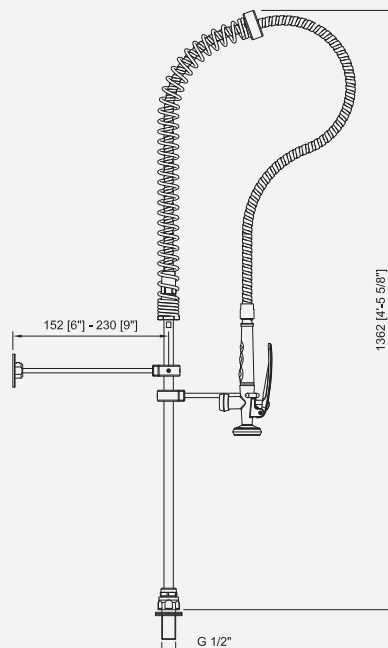

07101.2.B
235,00 €



07102.2.B

Grifo de sobremesa tipo ducha de dos águas

Torneira de área de trabalho tipo chuveiro de duas águas

Rubinetto soprapiano tipo doccia

Robinet douchette sur plan de travail à deux eaux

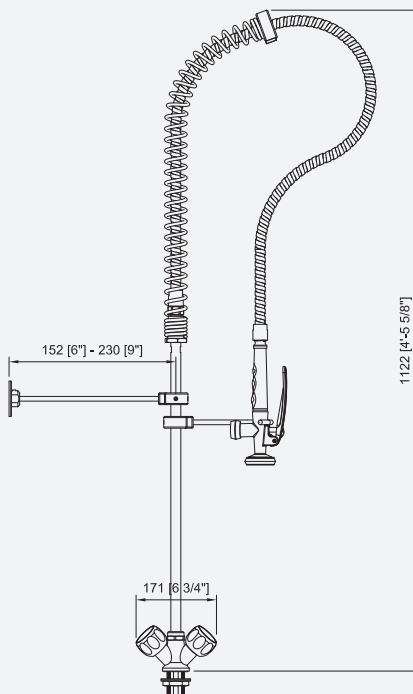

07102.2.B
305,00 €

07100.2.B

Grifo de sobremesa tipo ducha de dos águas de leva larga

Torneira de área de trabalho tipo chuveiro de duas águas um comando

Rubinetto soprapiano tipo doccia monocomando a leva lunga

Robinet douchette sur plan de travail à deux eaux, levier à coude

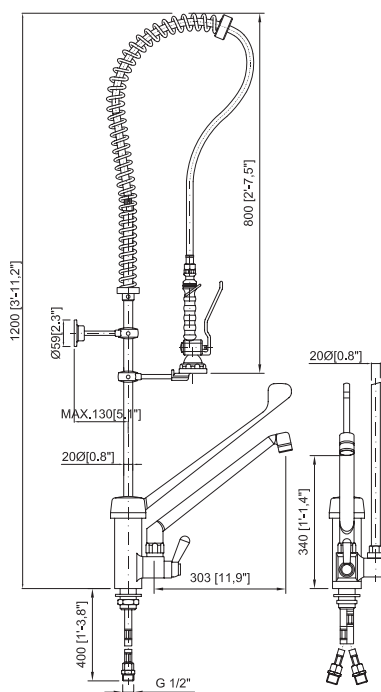

07100.2.B
450,00 €



07102.2.CC

- Grifo de sobremesa tipo ducha de dos aguas con caño
- Torneira de área de trabalho tipo chuveiro duas águas com bica
- Rubinetto soprapiano tipo doccia con bocchello
- Robinet douchette sur plan de travail, à deux eaux avec bec verseur

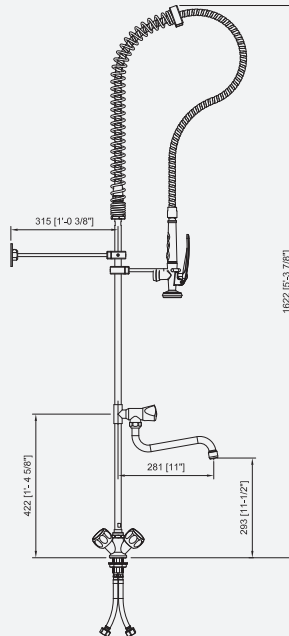

07102.2.CC
365,00 €

07102M.2.CC

- Grifo mural tipo ducha de dos aguas monomando con caño
- Torneira de parede tipo chuveiro de duas águas um comando com bica
- Rubinetto soprapiano tipo doccia monocomando con bocchello
- Robinet douchette mural, mono-commande, à deux eaux, avec bec verseur

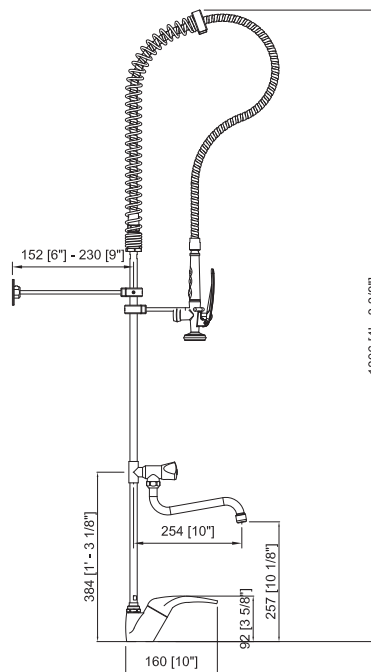

07102M.2.CC
365,00 €

- **SOLUCIONES
ANTIVANDÁLICAS**
- **SOLUÇÕES
ANTI-VANDALISMO**
- **SOLUZIONI
ANTIVANDALO**
- ◎ **SOLUTIONS
ANTI-VANDALISME**



○ GRIFERÍA PARA LAVABO

● RUBINETTI PER LAVABO

● TORNEIRAS PARA LAVATÓRIO

◎ ROBINETS POUR LAVABO

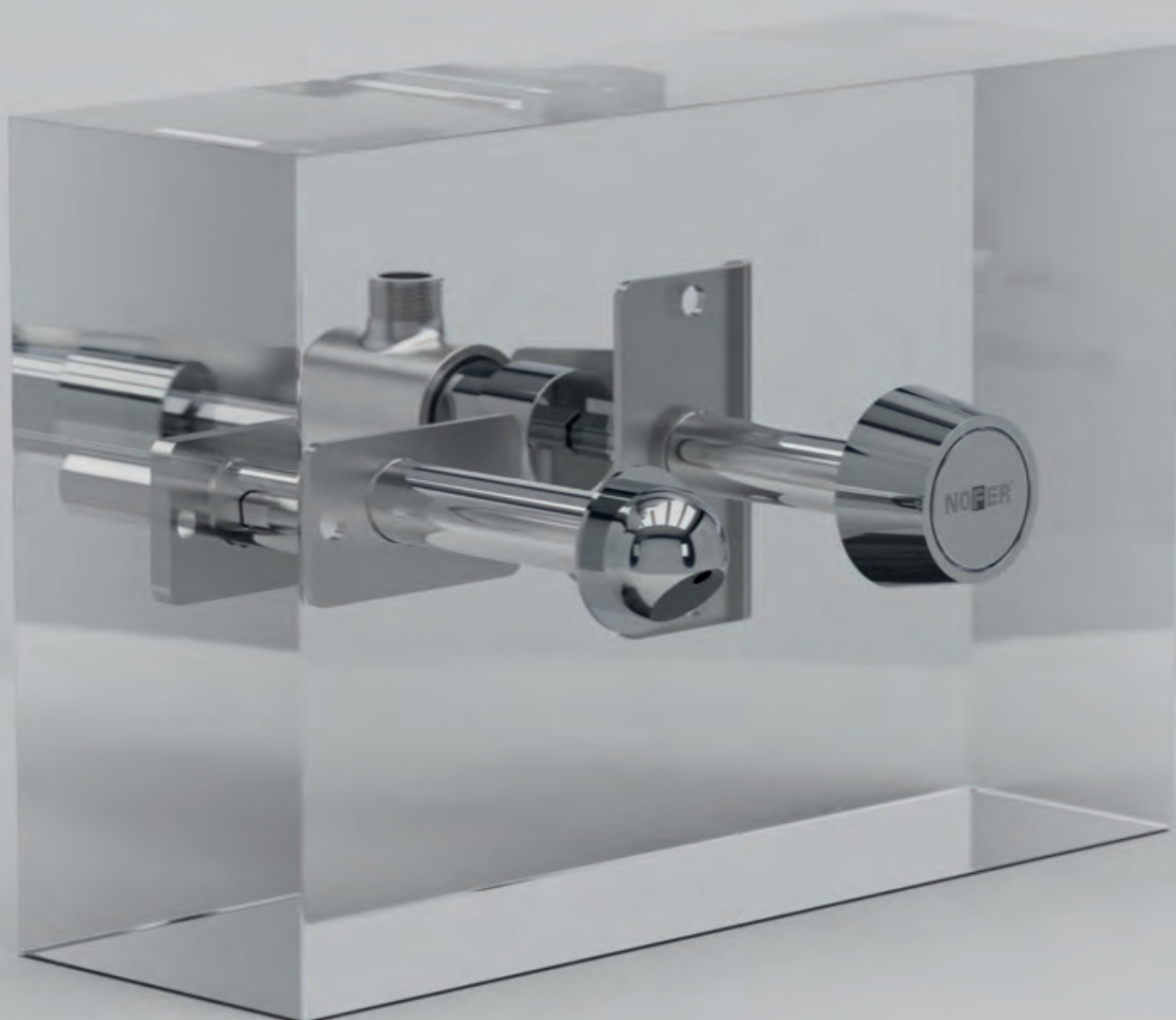



Trasmuro

Cuerpo de latón cromado, pulsador de acero inoxidable para instalación a través de muro

Tiempo de actuación 7 ± 3 s



Atrás da parede

Corpo de latão cromado, botão de pressão de aço inoxidável para instalação através da parede

Tempo de atuação 7 ± 3 s



Intramuro

Corpo in ottone cromato, pulsante in acciaio inox per installazione intramuro

Tempo di prestazione 7 ± 3 s



Traversée de mur

Corps en laiton chromé, bouton-poussoir en acier inoxydable pour installation à travers le mur

Durée de fonctionnement 7 ± 3 s

**07015.10.LA** | 115,15 €

- Conjunto antivandálico pulsación antiblocaje. Consumo LEED 1,89 l/min
- Conjunto antivandalismo pulsação anti-bloqueio. Consumo LEED 1,89 l/min
- Set antivandalo pressione antibloccaggio. Consumo LEED 1,89 l/min
- ◎ Ensemble anti-vandalisme pression anti-verrouillage. Consommation LEED 1,89 l/min

**07015.10.LN** | 100,15 €

- Conjunto antivandálico pulsación normal. Consumo LEED 1,89 l/min
- Conjunto antivandalismo pulsação normal. Consumo LEED 1,89 l/min
- Set antivandalo pressione normale. Consumo LEED 1,89 l/min
- ◎ Ensemble anti-vandalisme pression normale. Consommation LEED 1,89 l/min

**07013.A** | 57,40 €

- Grifo temporizado para conjunto antivandálico 07015.10.LA
- Torneira temporizada para conjunto antivandalismo 07015.10.LA
- Rubinetto temporizzato per set antivandalo 07015.10.LA
- ◎ Rubinetto temporizzato per lavabo set anti vandalismo 07015.10.LA

07013.K | 42,40 €

- Grifo temporizado para conjunto antivandálico 07015.10.LN
- Torneira temporizada para conjunto antivandalismo 07015.10.LN
- Rubinetto temporizzato per set antivandalo 07015.10.LN
- ◎ Rubinetto temporizzato per lavabo set anti vandalismo 07015.10.LN

- Los precios son para espesor de tabique de 10 cm otros espesores consultar precios
- I prezzi sono per uno spessore di tramezzo di 10 cm. Consultare i prezzi per altri spessori

- Os preços são para divisórias com espessura de 10cm. Consulte preços para outras espessuras
- ◎ Les Prix sont pour une épaisseur de cloison de 10cm. Consulter le Prix pour les autres épaisseurs





97001.07.A | 24,50 €



- Cartucho para grifos 07013.A
- Cartucho para torneiras 07013.A
- Cartuccia per rubinetti 07013.A
- Cartouche pour robinets 07013.A

97001.07.N | 21,20 €



- Cartucho para grifos 07013.K
- Cartucho para torneiras 07013.K
- Cartuccia per rubinetti 07013.K
- Cartouche pour robinets 07013.K

97418 | 7,75 €



- Soporte para conjunto antivandálico
- Suporte para conjunto antivandalismo
- Supporto per set antivandalo
- Support pour ensemble anti-vandalisme

07084.10.B | 50,00 €



- Pulsador para conjunto antivandálico
- Botão para conjunto antivandalismo
- Pulsante per gruppo antivandalo
- Bouton poussoir pour ensemble antivandalisme

07085.10.B | 70,00 €



- Pulsador plano para conjunto antivandálico
- Pulsador plano para conjunto antivandalismo
- Pulsante piano per set antivandalo
- Bouton poussoir plat pour ensemble anti-vandalisme



○ Pulsación normal ● Pulsação normal

● Pressione normal ⊙ Pression normale



○ Antiblocaje ● Anti-bloqueio

● Antibloccaggio ⊙ Anti-verrouillage



- Caños para conjuntos de lavabo tras muro
- Bicos para conjuntos de lavatorios tras muro
- Bocchello per set lavabo retro parete
- Becs pour ensembles de lavabo à travers le mur

07022.10.B | 50,00 €



- Caño para conjunto antivandálico
- Bico para conjunto antivandalismo
- Becco per set antivandalo
- Bec pour ensemble antivandalisme

○ Los precios son para espesor de tabique de 10 cm otros espesores consultar precios

● Os preços são para divisórias com espessura de 10cm. Consulte preços para outras espessuras

● I prezzi sono per uno spessore di tramezzo di 10cm. Consultare i prezzi per altri spessori.

● Les Prix sont pour une épaisseur de cloison de 10cm. Consulter le Prix pour les autres épaisseurs

- Ejemplo de instalación conjunto de lavabo tras muro 07015.10.LA
- Exemplo de instalação de um lavatório atrás de uma parede 07015.10.LA
- Esempio di installazione di un lavabo posizionato dietro una parete 07015.10.LA
- Exemple d'installation d'un lavabo derrière un mur 07015.10.LA

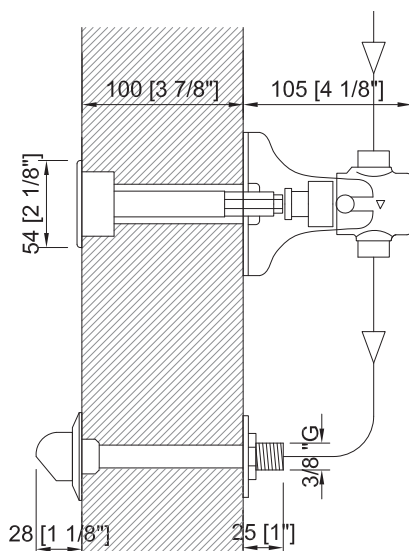



○ Instalación empotrada

Caja de acero inoxidable AISI 304 para empotrar

Construcción interior de latón

● Instalação encastrada

Caixa de aço inoxidável AISI 304 para incorporação

Construção interna em latão

● Installazione ad incasso

Cassa in acciaio inox AISI 304 per incasso

Costruzione interna in ottone

◎ Installation encastrée

Boîtier en acier inoxydable AISI 304 pour encastrer

Construction intérieure en laiton



- Grifo temporizado mural para lavabo con caja de acero inoxidable encastrada
- Rubinetto temporizzato per lavabo con cassa in acciaio inox per incasso
- Torneira temporizada para lavatorio de bancada com caixa de aço encastrada
- ◎ Robinet temporisé pour lavabo avec boîtier en acier inoxydable encastrée

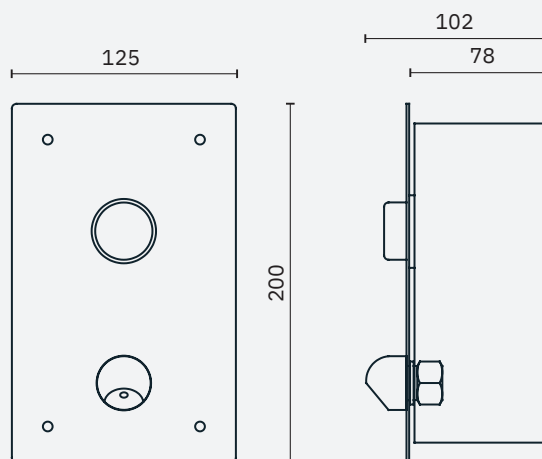

07090.LA | 170,00 €



- Pulsación antibloqueaje. Consumo LEED 1,89 l/min
- Pulsação anti-bloqueio. Consumo LEED 1,89 l/min
- Pressione antibloccaggio. Consumo LEED 1,89 l/min
- ◎ Pression anti-verrouillage. Consommation LEED 1,89 l/min



07090.LN | 165,00 €



- Pulsación normal. Consumo LEED 1,89 l/min
- Pulsação normal. Consumo LEED 1,89 l/min
- Pressione normale. Consumo LEED 1,89 l/min
- ◎ Pression normale. Consommation LEED 1,89 l/min

97001.07.A | 24,50 €



- Cartucho para grifo 07090.LA
- Cartucho para torneiras 07090.LA
- Cartuccia per rubinetti 07090.LA
- ◎ Cartouche pour robinets 07090.LA

97001.07.N | 21,20 €



- Cartucho para grifos 07090.LN
- Cartucho para torneiras 07090.LN
- Cartuccia per rubinetti 07090.LN
- ◎ Cartouche pour robinets 07090.LN



○ Pulsación normal ● Pulsação normal ○ Antibloqueaje ● Anti-bloqueio

● Pressione normal ◎ Pression normale ● Antibloccaggio ◎ Anti-verrouillage

○ GRIFERÍA PARA
DUCHA

● RUBINETTI PER
DOCCIA

● TORNEIRAS PARA
DUCHE

◎ ROBINETS POUR
DOUCHE

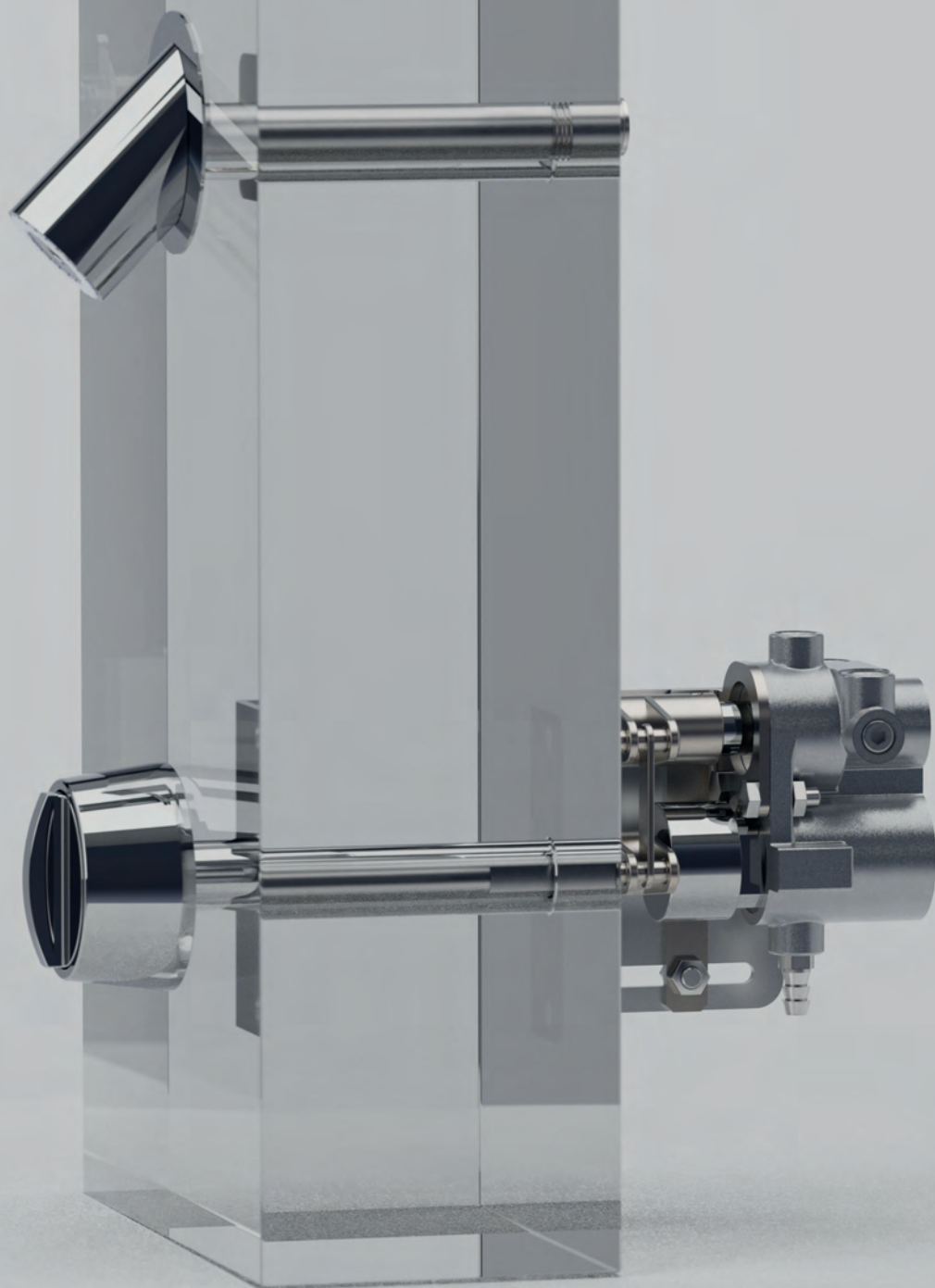



Tras muro

Cuerpo de latón cromado, pulsador de acero inoxidable para instalación a través de muro

Tiempo de actuación
20 ± 10 s



Tras muro

Corpo de latão cromado, botão de pressão de aço inoxidável para instalação através da parede

Tempo de atuação 20 ± 10 s



Intramuro

Corpo in ottone cromato, pulsante in acciaio inox per installazione a parete

Tempo di attivazione
20 ± 10 s



Traversée de mur

Corps en laiton chromé, bouton-poussoir en acier inoxydable pour installation à travers le mur

Durée de fonctionnement
20 ± 10 s



○ Soluciones antivandálicas

● Soluções anti-vandalismo

● Soluzioni antivandalo

⊙ Solutions anti-vandalisme



07018.10.LA | 117,65 €

- Conjunto antivandálico pulsación antiblocaje. Consumo LEED 6 l/min
- Conjunto antivandalismo pulsação anti-bloqueio. Consumo LEED 6 l/min
- Set antivandalo pressione antibloccaggio. Consumo LEED 6 l/min
- ⊙ Ensemble anti-vandalisme pression anti-verrouillage. Consommation LEED 6 l/min



07018.10.LN | 102,65 €

- Conjunto antivandálico pulsación normal. Consumo LEED 6 l/min
- Conjunto antivandalismo pulsação normal. Consumo LEED 6 l/min
- Set antivandalo pressione normale. Consumo LEED 6 l/min
- ⊙ Ensemble anti-vandalisme pression normale. Consommation LEED 6 l/min



07018.10.A | 116,65 €

- Conjunto antivandálico pulsación antiblocaje
- Conjunto antivandalismo pulsação anti-bloqueio
- Set antivandalo pressione antibloccaggio
- ⊙ Ensemble anti-vandalisme pression anti-verrouillage



07018.10.N | 101,65 €

- Conjunto antivandálico pulsación normal
- Conjunto antivandalismo pulsação normal
- Set antivandalo pressione normale
- ⊙ Ensemble anti-vandalisme pression normale.



07670.LA | 59,90 €



- Grifo temporizado para conjunto antivandálico 07018.10.LA
- Torneira temporizada para conjunto antivandalismo 07018.10.LA
- Rubinetto temporizzato per set anti vandalismo 07018.10.LA
- ⊙ Robinet temporisé pour ensemble anti vandalisme 07018.10.LA

07670.A | 58,90 €



- Grifo temporizado antiblocaje para conjunto antivandálico 07018.10.A
- Torneira temporizada anti bloqueio para conjunto antivandalismo 07018.10.A
- Rubinetto temporizzato antibloccaggio per set anti vandalismo 07018.10.A
- ⊙ Robinet temporisé anti-verrouillage pour ensemble anti vandalisme 07018.10.A



07670.LN | 44,90 €



Grifo temporizado para conjunto antivandálico 07018.10.LN

Torneira temporizada para conjunto antivandalismo 07018.10.LN

Rubinetto temporizzato per set antivandalo 07018.10.LN

Rubinetto temporizzato per lavabo set anti vandalismo 07018.10.LN

07670.N | 43,90 €



Grifo temporizado un agua para conjunto antivandálico 07018.10.N

Torneira temporizada antibloqueio para conjunto antivandalismo 07018.10.N

Rubinetto temporizzato antibloccaggio per set antivandalo 07018.10.N

Robinet temporisé anti-verrouillage pour ensemble anti-vandalisme 07018.10.N

○ Los precios son para espesor de tabique de 10 cm otros espesores consultar precios

● I prezzi sono per uno spessore di tramezzo di 10 cm. Consultare i prezzi per altri spessori

● Os preços são para divisórias com espessura de 10cm. Consulte preços para outras espessuras

⊙ Les Prix sont pour une épaisseur de cloison de 10cm. Consulter le Prix pour les autres épaisseurs



○ Pulsación normal

● Pulsação normal



○ Antiblocaje

● Anti-bloqueio

● Pressione normal

⊙ Pression normale



● Antibloccaggio

⊙ Anti-verrouillage



97001.25.A | 32,90 €



- Cartucho temporizado para grifo antivandálico 07670.LA y 07670.A
- Cartucho temporizado para torneira antivandalismo 07670.LA e 07670.A
- Cartuccia temporizzata per rubinetto antivandalo 07670.LA e 07670.A
- Cartouche temporisée pour robinet antivandalisme 07670.LA et 07670.A

97001.25.N | 29,60 €



- Cartucho temporizado para grifo antivandálico 07670.LN y 07670.N
- Cartucho temporizado para torneira antivandalismo 07670.LN e 07670.N
- Cartuccia temporizzata per rubinetto antivandalo 07670.LN e 07670.N
- Cartouche temporisée pour robinet antivandalisme 07670.LN et 07670.N

97418 | 7,75 €



- Soporte para conjunto antivandálico
- Suporte para conjunto antivandalismo
- Supporto per set antivandalo
- Support pour ensemble antivandalisme

07084.10.B | 50,00 €



- Pulsador para conjunto antivandálico
- Botão para conjunto antivandalismo
- Pulsante per gruppo antivandalo
- Bouton poussoir pour ensemble antivandalisme

07085.10.B | 70,00 €



- Pulsador plano para conjunto antivandálico
- Pulsador plano para conjunto antivandalismo
- Pulsante piano per set antivandalo
- Bouton poussoir plat pour ensemble anti-vandalisme



○ Pulsación normal ● Pulsação normal



○ Antiblocaje ● Anti-bloqueio

● Pressione normal ● Pression normale

● Antibloccaggio ● Anti-verrouillage

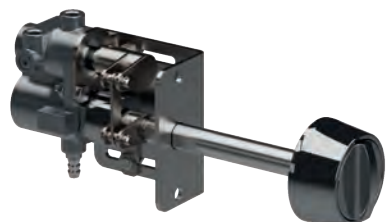

07017.10.GLA | 212,50 €

- Conjunto antivandálico pulsación antiblocaje. Consumo LEED 6 l/min. Sistema antilegionella
- Conjunto antivandalismo pulsação anti-bloqueio. Consumo LEED 6 l/min. Sistema antilegionella
- Set antivandalo pressione antibloccaggio. Consumo LEED 6 l/min. Sistema antilegionella
- ⊙ Ensemble anti-vandalisme pression anti-verrouillage. Consommation LEED 6 l/min. Système anti-legionellose



07017.10.GLN | 207,50 €

- Conjunto antivandálico pulsación normal. Consumo LEED 6 l/min. Sistema antilegionella
- Conjunto antivandalismo pulsação normal. Consumo LEED 6 l/min. Sistema antilegionella
- Set antivandalo pressione normale. Consumo LEED 6 l/min. Sistema antilegionella
- ⊙ Ensemble anti-vandalisme pression normale. Consommation LEED 6 l/min. Système anti-legionellose



97345.GLA | 114,00 €



- Grifo temporizado para conjunto antivandálico 07017.10.GLA. Sistema antilegionella
- Torneira temporizada para conjunto antivandalismo 07017.10.GLA. Sistema antilegionella
- Rubinetto temporizzato per set anti vandalismo 07017.10.GLA. Sistema antilegionella
- ⊙ Robinet temporisé pour ensemble anti vandalisme 07017.10.GLA. Système anti-legionellose



97345.GLN | 109,00 €



- Grifo temporizado para conjunto antivandálico 07017.10.GLN. Sistema antilegionella
- Torneira temporizada para conjunto antivandalismo 07017.10.GLN. Sistema antilegionella
- Rubinetto temporizzato per set anti vandalismo 07017.10.GLN. Sistema antilegionella
- ⊙ Robinet temporisé pour ensemble anti vandalisme 07017.10.GLN. Système anti-legionellose

- Los precios son para espesor de tabique de 10 cm otros espesores consultar precios
- I prezzi sono per uno spessore di tramezzo di 10 cm. Consultare i prezzi per altri spessori

- Os preços são para divisórias com espessura de 10cm. Consulte preços para outras espessuras
- ⊙ Les Prix sont pour une épaisseur de cloison de 10cm. Consulter le Prix pour les autres épaisseurs





97001.25.A | 32,90 €



- Cartucho temporizado para grifo antivandálico 97345.GLA
- Cartucho temporizado para torneira antivandalismo 97345.GLA
- Cartuccia temporizzata per rubinetto antivandalo 97345.GLA
- ⊙ Cartouche temporisée pour robinet antivandalisme 97345.GLA

97001.25.N | 29,60 €



- Cartucho temporizado para grifo antivandálico 97345.GLN
- Cartucho temporizado para torneira antivandalismo 97345.GLN
- Cartuccia temporizzata per rubinetto antivandalo 97345.GLN
- ⊙ Cartouche temporisée pour robinet antivandalisme 97345.GLN

97438 | 19,50 €



- Conjunto de levas
- Conjunto de came
- Camma set
- ⊙ Came set

97347 | 19,00 €



- Soportes para conjunto antivandálico
- Suportes para conjunto antivandalismo
- Supporti per set antivandalo
- ⊙ Supports pour ensemble antivandalisme

07068.10.B | 60,00 €



- Pulsador para conjunto antivandálico
- Botão para conjunto antivandalismo
- Pulsante per gruppo antivandalo
- ⊙ Bouton pousseur pour ensemble antivandalisme



- Rociador para conjuntos de ducha instalación tras muro
- Cabeça de chuveiro para conjuntos instalação atrás da parede
- Soffione per set doccia installazione retro parete
- Pommes de douche pour ensembles de douche

07075.10.B | 50,00 €



- Rociador de ducha para conjunto antivandálico
- Cabeça de chuveiro para conjunto antivandalismo
- Soffione doccia per set antivandalo
- Pomme de douche pour ensemble antivandalisme

○ Los precios son para espesor de tabique de 10 cm otros espesores consultar precios

● Os preços são para divisórias com espessuras de 10cm. Consulte preços para otras espesuras

● I prezzi sono per uno spessore di tramezzo di 10cm. Consultare i prezzi per altri spessori.

● Les Prix sont pour une épaisseur de cloison de 10cm. Consulter le Prix pour les autres épaisseurs

- Ejemplo de instalación conjunto de ducha tras muro 07018.10.LA
- Exemplo de instalação de um conjunto de chuveiro atrás de uma parede 07018.10.LA
- Esempio di installazione di un montaggio doccia retro parete 07018.10.LA
- Exemple d'installation d'un ensemble douche derrière un mur 07018.10.LA

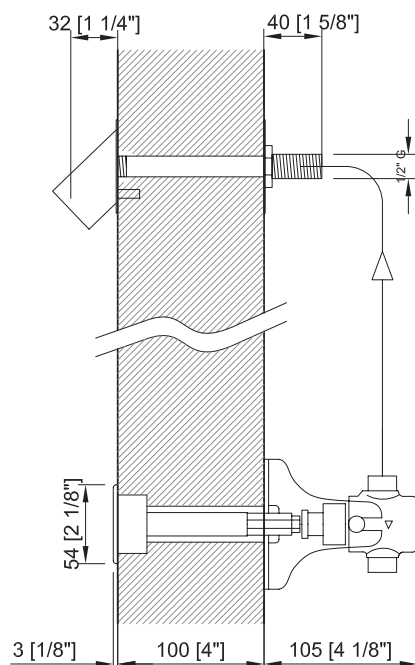



- Rociador para conjuntos de ducha instalación tras muro
- Cabeça de chuveiro para conjuntos de duche instalação atrás da parede
- Soffione per set doccia installazione dietro la parete
- Arroseur pour ensembles de douche installation derrière le mur

07075.10.B | 50,00 €



- Rociador de ducha para conjunto antivandálico
- Cabeça de chuveiro para conjunto antivandalismo
- Soffione doccia per set antivandalo
- Pomme de douche pour ensemble antivandalisme

○ Los precios son para espesor de tabique de 10 cm otros espesores consultar precios

● Os preços são para divisórias com espessura de 10cm. Consulte preços para otras espesuras

● I prezzi sono per uno spessore di tramezzo di 10cm. Consultare i prezzi per altri spessori.

● Les Prix sont pour une épaisseur de cloison de 10cm. Consulter le Prix pour les autres épaisseurs

- Ejemplo de instalación conjunto ducha tras muro 07017.10.GLA
- Exemplo de instalação de um conjunto de chuveiro tras muro 07017.10.GLA
- Esempio di montaggio doccia installazione retro parete 07017.10.GLA
- Exemple d'installation d'un ensemble douche à travers le muro 07017.10.GLA

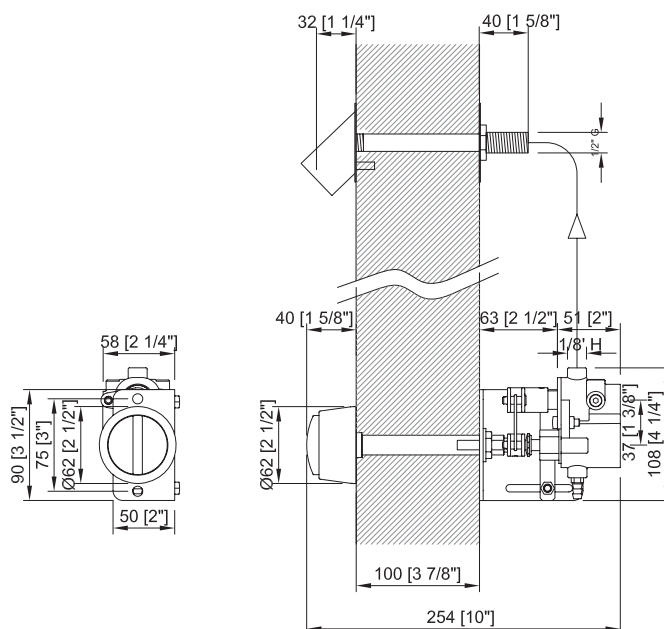



○ Instalación empotrada

Cuerpo interior de latón cromado, pulsador de acero inoxidable

Caja de acero inoxidable AISI 304

● Instalação encastrada

Corpo interno de latão cromado, botão de pressão de aço inoxidável

Caixa de aço inoxidável AISI 304

● Installazione ad incasso

Costruzione interna in ottone

Cassa in acciaio inox AISI 304 per incasso

⊙ Installation encastrée

Corps intérieur en laiton chromé, bouton poussoir en acier inoxydable

Boîtier en acier inoxydable AISI 304

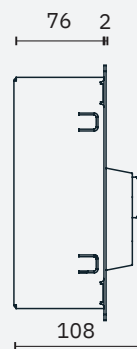
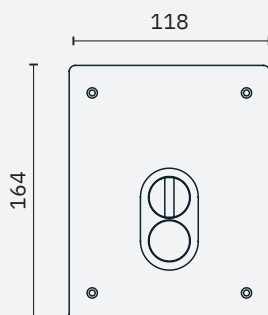

07017.LA

254,90 €



○ Conjunto antivandálico pulsación antiblocaje.
Consumo LEED 6 l/min

● Conjunto antivandalismo pulsação anti-bloqueio.
Consumo LEED 6 l/min

● Set antivandalo pressione antibloccaggio.
Consumo LEED 6 l/min

⊙ Ensemble anti-vandalisme pression anti-verrouillage.
Consommation LEED 6 l/min



07017.GLA

284,90 €



○ Conjunto antivandálico pulsación antiblocaje y sistema antilegionella.
Consumo LEED 6 l/min

● Conjunto antivandalismo pulsação anti-bloqueio e sistema antilegionella.
Consumo LEED 6 l/min

● Set antivandalo pressione antibloccaggio e sistema antilegionella.
Consumo LEED 6 l/min

⊙ Ensemble anti-vandalisme pression anti-verrouillage et système anti-legionellose.
Consommation LEED 6 l/min



07017.LN

249,90 €



○ Conjunto antivandálico pulsación normal.
Consumo LEED 6 l/min

● Conjunto antivandalismo pulsação normal.
Consumo LEED 6 l/min

● Set antivandalo pressione normale.
Consumo LEED 6 l/min

⊙ Ensemble anti-vandalisme pression normale.
Consommation LEED 6 l/min



07017.GLN

279,90 €



○ Conjunto antivandálico pulsación normal y sistema antilegionella.
Consumo LEED 6 l/min

● Conjunto antivandalismo pulsação normal e sistema antilegionella.
Consumo LEED 6 l/min

● Set antivandalo pressione normale e sistema antilegionella.
Consumo LEED 6 l/min

⊙ Ensemble anti-vandalisme pression normale et système anti-legionellose.
Consommation LEED 6 l/min





97345.LA | 84,00 €

- Grifo mezclador de ducha pulsación antiblocaje. Consumo LEED 6 l/min
- Misturador para chuveiro pulsação anti-bloqueio. Consumo LEED 6 l/min
- Miscelatore doccia pressione antibloccaggio. Consumo LEED 6 l/min
- ⊙ Robinet de douche anti-verrouillage. Consommation LEED 6 l/min



97345.GLA | 114,00 €

- Grifo mezclador de ducha pulsación antiblocaje y sistema antilegionella. Consumo LEED 6 l/min
- Misturador para chuveiro pulsação anti-bloqueio e sistema antilegionella. Consumo LEED 6 l/min
- Miscelatore doccia pressione antibloccaggio e sistema antilegionella. Consumo LEED 6 l/min
- ⊙ Robinet de douche anti-verrouillage et système anti-legionellose. Consommation LEED 6 l/min



97345.LN | 79,00 €

- Grifo mezclador de ducha pulsación normal. Consumo LEED 6 l/min
- Misturador para chuveiro pulsação normal. Consumo LEED 6 l/min
- Miscelatore doccia pressione normale e sistema antilegionella. Consumo LEED 6 l/min
- ⊙ Robinet de douche anti-verrouillage et système anti-legionellose. Consommation LEED 6 l/min



97345.GLN | 109,00 €

- Grifo mezclador de ducha pulsación normal y sistema antilegionella. Consumo LEED 6 l/min
- Misturador para chuveiro pulsação normal e sistema antilegionella. Consumo LEED 6 l/min
- Miscelatore doccia pressione normale e sistema antilegionella. Consumo LEED 6 l/min
- ⊙ Robinet de douche pression normale et système anti-legionellose. Consommation LEED 6 l/min



97317 | 120,00 €



- Conjunto de caja y embellecedor en acero inoxidable
- Conjunto de caixa e acabamento em aço inoxidável
- Gruppo di cassa e finiture in acciaio inossidabile
- ⊙ Ensemble boîtier et cache en acier inoxydable

97301 | 32,40 €



- Protector para caja 97317
- Protetor para caixa 97317
- Protettore per scatola 97317
- ⊙ Protecteur pour boîtier 97317

97307 | 18,50 €



- Mando selección temperatura
- Botão de seleção de temperatura
- Selettore della temperatura
- ⊙ Sélecteur de température

97001.25.A | 32,90 €



- Cartucho para grifos 97345.LA y 97345.GLA
- Cartucho para torneiras 97345.LA e 97345.GLA
- Cartuccia per rubinetti 97345.LA e 97345.GLA
- ⊙ Cartouche pour robinets 97345.LA et 97345.GLA

97001.25.N | 29,60 €



- Cartucho para grifos 97345.LN y 97345.GLN
- Cartucho para torneiras 97345.LN e 97345.GLN
- Cartuccia per rubinetti 97345.LN e 97345.GLN
- ⊙ Cartouche pour robinets 97345.LN et 97345.GLN





- Ejemplo de instalación conjunto ducha empotrada 07017.LA
- Exemplo de instalação de um conjunto de chuveiro encastrado 07017.LA
- Esempio di montaggio doccia installazione ad incasso 07017.LA
- Exemple d'installation d'un ensemble douche encastrée 07017.LA

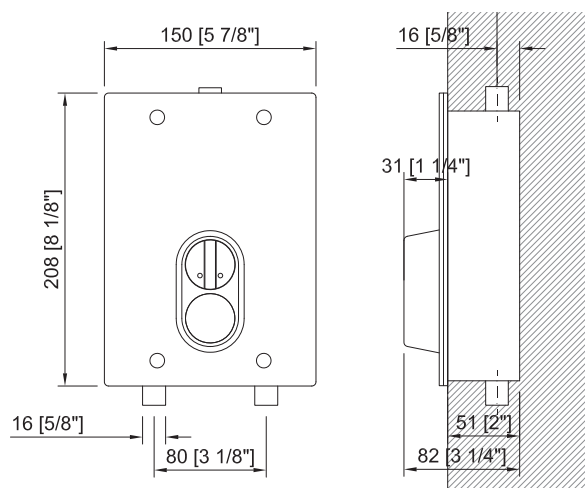



○ GRIFERÍA
PARA INODORO

● RUBINETTI
PER WC

● TORNEIRAS
PARA INODORO

◎ ROBINETS
POUR TOILETTE

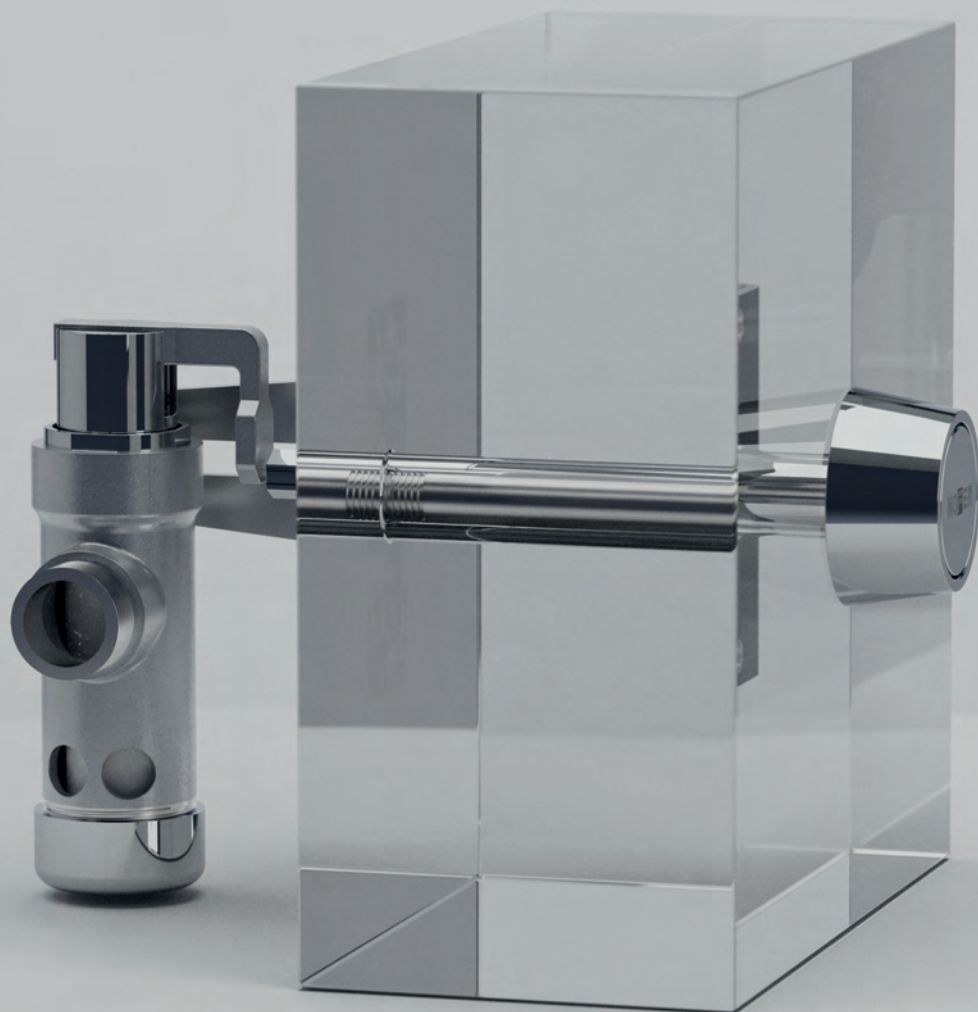



Tras muro

Antivandálico para instalación a través de muro

Robusto y duradero, adecuado para entornos de alta seguridad

Tiempo de actuación 10 s

Caudal 25 l/min



Atrás da parede

Resistente a vandalismo para instalação através da parede

Robusto e durável, adequado para ambientes de alta segurança

Tempo de atuação 10 s

Fluxo 25 l/min



Intramuro

Robusto e durevole, adatto per ambienti ad alta sicurezza

Robusto e duraturo, adatto per ambienti ad alta sicurezza

Tempo di prestazione 10 s

Portata 25 l/min



Traversée de mur

Anti-vandalisme, installation à travers le mur

Robuste et durable, approprié aux environnements de haute sécurité

Durée de fonctionnement 10 s

Débit 25 l/min

**07016.10.B** | 116,80 €

- Conjunto antivandálico para inodoro. Instalación tras muro
- Conjunto antivandálico para inodoro. Instalação tras muro
- Set antivandalo per WC. Installazione retro parete
- ◎ Ensemble pour WC anti-vandalisme. Installation à travers le mur

**07081.K** | 59,00 €

- Fluxor para conjunto antivandálico 07016.10.B
- Fluxor para conjunto antivandalismo 07016.10.B
- Flussometro per set antivandalo 07016.10.B
- ◎ Robinet de chasse pour ensemble antivandalisme 07016.10.B

07099.B | 9,50 €

- Conjunto de pistón para toda la gama de fluxores
- Set pistone per l'intera gamma di flussometri
- Conjunto de pistão para toda a gama de fluxantes
- ◎ Ensemble de piston pour toute la gamme de robinets de chasse

97415 | 7,80 €

- Soporte para conjunto antivandálico
- Suporte para conjunto antivandalismo
- Supporto per set antivandalo
- ◎ Support pour ensemble antivandalisme

07084.10.B | 50,00 €

- Pulsador para conjunto antivandálico
- Botão para conjunto antivandalismo
- Pulsante per gruppo antivandalo
- ◎ Bouton poussoir pour ensemble antivandalisme

07085.10.B | 70,00 €

- Pulsador plano para conjunto antivandálico
- Pulsador plano para conjunto antivandalismo
- Pulsante piano per set antivandalo
- ◎ Bouton poussoir plat pour ensemble antivandalisme

○ Los precios son para espesor de tabique de 10 cm otros espesores consultar precios

● I prezzi sono per uno spessore di tramezzo di 10 cm. Consultare i prezzi per altri spessori

● Os preços são para divisórias com espessura de 10cm. Consulte preços para outras espessuras

◎ Les Prix sont pour une épaisseur de cloison de 10cm. Consulter le Prix pour les autres épaisseurs





Instalación empotrada

Caja de acero inoxidable AISI 304 para empotrar

Construcción interior de latón

Instalação encastrada

Caixa de aço inoxidável AISI 304 para incorporação

Construção interna em latão

Installazione ad incasso

Cassa in acciaio inox AISI 304 per incasso

Costruzione interna in ottone

Installation encastrée

Boîtier en acier inoxydable AISI 304 pour encastrer

Construction intérieure en laiton

07083.28.B

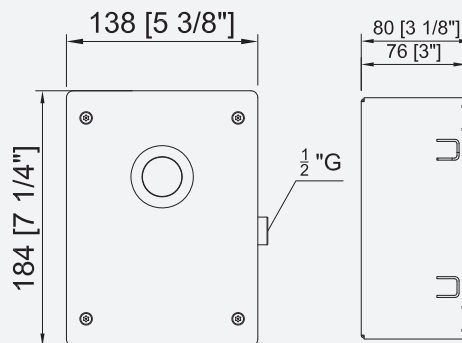

○ Fluxor temporizado mural entrada 1/2"G sin llave de paso. Instalación encastrada. Conexión 28 mm

● Flussometro temporizzato a parete, ingresso 1/2"G senza valvola di intercettazione. Installazione ad incasso. Connessione 28 mm

● Fluxo temporizado de parede entrada 1/2"G sem chave de passo. Instalação embutida. Conexão 28 mm

⊙ Robinet de chasse temporisé mural 1/2"G sans vanne d'arrêt. Installation encastrée. Connexion 28 mm

07083.28.B
195,00 €

07083.32.B

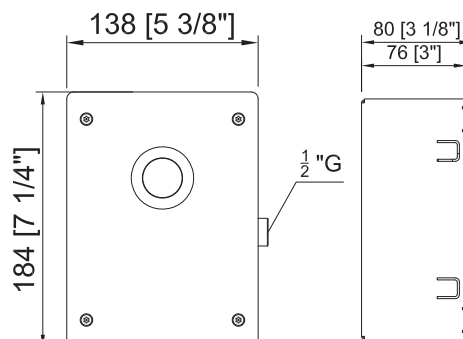

○ Fluxor temporizado mural entrada 1/2"G sin llave de paso. Instalación encastrada. Conexión 32 mm

● Flussometro temporizzato a parete, ingresso 1/2"G senza valvola di intercettazione. Installazione ad incasso. Connessione 32 mm

● Fluxo temporizado de parede entrada 1/2"G sem chave de passo. Instalação embutida. Conexão 32 mm

⊙ Robinet de chasse temporisé mural 1/2"G sans vanne d'arrêt. Installation encastrée. Connexion 32 mm

07083.32.B
205,00 €

○ Expositores de grifería

● Expositores de torneiras

NEW • NUEVO • NUOVO • NOUVEAU



○ Expositor de sobremesa

Expositor metálico de sobremesa
‡ 510 ↔ 305 ↗ 325 mm (montado)

Fácil montaje

Los expositores pueden montarse con productos escogidos por el cliente en colaboración con el comercial de zona.

● Expositor na área de trabalho

Expositor metálico na área de trabalho.
‡ 510 ↔ 305 ↗ 325 mm (montado)

Montagem fácil.

Os expositores podem montar-se com produtos escolhidos pelo cliente em colaboração com o comercial de zona.

● Espositore da banco

Espositore metallico da banco
‡ 510 ↔ 305 ↗ 325 mm (montato)

Montaggio semplice

Gli espositori possono montarsi con prodotti scelti dal cliente in collaborazione con l'agente di zona

● Présentoir de table

Présentoir métallique de table
‡ 510 ↔ 305 ↗ 325 mm (monté)

Montage facile.

Les présentoirs peuvent être montés avec des produits sélectionnés par le client sur collaboration du commercial chargé de la zone

● Espositori di rubinetti

● Présentoir de robinets



○ Expositor de pie

Expositor metálico de sobremesa
‡ 1750 ↔ 300 ↗ 350 mm (montado)

Fácil montaje.

Los expositores pueden montarse con productos escogidos por el cliente en colaboración con el comercial de zona.

● Expositor de pé

Expositor metálico na área de trabalho
‡ 1750 ↔ 300 ↗ 350 mm (montado)

Montagem fácil.

Os expositores podem montar-se com produtos escolhidos pelo cliente em colaboração com o comercial de zona.

● Espositore a pavimento

Espositore metallico da banco
‡ 1750 ↔ 300 ↗ 350 mm (montato)

Montaggio semplice.

Gli espositori possono montarsi con prodotti scelti dal cliente in collaborazione con l'agente di zona.

● Présentoir de pied





Présentoir métallique de table
‡ 1750 ↔ 300 ↗ 350 mm (monté)





Montage facile.



Les présentoirs peuvent être montés avec des produits sélectionnés par le client sur collaboration du commercial chargé de la zone.

○ Repuestos ● Peças de reposição
● Pezzi di ricambio ○ Pièces de rechange

AIREADORES / AERADORES
AERATORI / AÉRATEURS

Ø 24 mm					
		○ Caudal ● Fluxo ● Flusso ○ Débit	○ Tipo salida ● Tipo de saída ● Tipo di uscita ○ Type de sortie	REF.	
	STANDARD (B)	6 l/min.		97050	12,00 €
	ECO (EB)	3 l/min.		97061	12,00 €
	LEED (LB)	1,89 l/min.		97062	12,00 €
	LOW (WB)	1,32 l/min.		97165.1	12,00 €

Ø 24 mm (○ Antivandálico ● Anti-vandalismo ● Antivandalo ○ Antivandalisme)						
		○ Caudal ● Fluxo ● Flusso ○ Débit	○ Tipo salida ● Tipo de saída ● Tipo di uscita ○ Type de sortie	REF.	○ Llave ● Chave ● Chiave ○ Clé	
	STANDARD (B)	6 l/min.		97050.1	099170000	9,00 €
	ECO (EB)	3 l/min.		97825		9,00 €
	LEED (LB)	1,89 l/min.		97065		9,00 €
	LOW (WB)	1,32 l/min.		97165.2		9,00 €

Ø 16,5 mm (○ Antivandálico ● Anti-vandalismo ● Antivandalo ○ Antivandalisme)						
		○ Caudal ● Fluxo ● Flusso ○ Débit	○ Tipo salida ● Tipo de saída ● Tipo di uscita ○ Type de sortie	REF.	○ Llave ● Chave ● Chiave ○ Clé	
	ECO (EB)	3 l/min.		97825.1	099171000	9,00 €
	LEED (LB)	1,89 l/min.		97065.1		9,00 €
	LOW (WB)	1,32 l/min.		97165.3		9,00 €

○ Reguladores de caudal (1/2" G) ● Regulador de fluxo (1/2" G) ● Regolatore di flusso (1/2" G) ○ Régulateur de débit (1/2" G)

	○ Caudal ● Fluxo ● Flusso ○ Débit	REF.	
	2 l/min.	97280.02	9,00 €
	3 l/min.	97280.03	9,00 €
	4 l/min.	97280.04	9,00 €
	5 l/min.	97280.05	9,00 €
	6 l/min.	97280.06	9,00 €

○ Repuestos

● Peças de reposição

● Pezzi di ricambio

◎ Pièces de rechange

VÁLVULA ANTIRRETORNO / VÁLVULA ANTIRRETORNO
VALVOLA ANTIRITORNO / VALVE ANTI-RETOUR

97131.38	3/8"G	10,00 €
97131.12	1/2"G	12,00 €
97900.BL	○ 3/8"G hembra 1/2"G macho ● 3/8"G fêmea 1/2"G macho ● 3/8"G femmina 1/2"G maschio ◎ 3/8"G femelle 1/2"G mâle	10,00 €
97900.RD	○ 3/8"G hembra 1/2"G macho ● 3/8"G fêmea 1/2"G macho ● 3/8"G femmina 1/2"G maschio ◎ 3/8"G femelle 1/2"G mâle	10,00 €

VÁLVULA MEZCLADORA / VÁLVULA MISTURADORA
VALVOLA MISCELATRICE / VANNE MÉLANGEUR



07017.B	36,80 €
---------	---------

PARA GRIFOS DE PALANCA
PARA TORNEIRAS DE ALAVANCA
PER RUBINETTI A LEVA / POUR ROBINETS À LEVIER

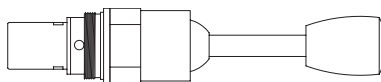

97001.P	42,50 €
---------	---------

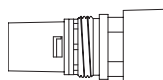





○ CONDICIONES DE VENTA

Las descripciones y fotografías contenidas en nuestro catálogo deberán entenderse únicamente a nivel informativo. Nuestra política es la de mejorar continuamente los productos, por ello nos reservamos el derecho de modificar las especificaciones sin previo aviso.

PRECIOS

Los precios no incluyen IVA ni otros impuestos. Los precios del catálogo podrán ser modificados sin previo aviso y son válidos según tarifa vigente el día de la expedición.

PEDIDOS

Todos los pedidos deben formalizarse mediante documento escrito.

Imprescindible para la fabricación especial:

- Adjuntar croquis con las medidas del producto solicitado.
- Abonar el 50% del importe en el momento de aceptación del pedido. El resto se abonará según las condiciones pactadas.
- Los precios no incluyen la instalación ni su puesta en marcha.

PLAZOS DE ENTREGA

- Quedando supeditada la mercancía incluida en el presente catálogo, a un proceso de fabricación del producto solicitado por el comprador, el plazo de entrega facilitado por NOFER, S.L. tendrá el carácter de orientativo o aproximado en el tiempo.
- Los eventuales retrasos en la entrega no podrán dar lugar a penalización alguna o indemnización por daños y perjuicios, ni facultarán al comprador para anular el pedido.

TRANSPORTE DE LA MERCANCÍA

- Cuando la mercancía viaje a porte debido, NOFER, S.L. queda exonerado de las posibles taras o defectos que pudieran ser imputables al transporte de la mercancía.
- Cuando la mercancía viaje a porte pagado, el cliente tiene que notificarle a NOFER, S.L. por escrito dentro de las 24 horas siguientes a la recepción de la mercancía, cualquier defecto o tara imputable a la agencia de transportes para facilitar la reclamación de la responsabilidad de acuerdo a la Ley 16/1987 de Ordenación de los Transportes terrestres y RD 1.111/1990 por el que se aprueba el reglamento de la LOTT.
- La reclamación contra el porteador por daño o avería, deberá hacerse en el acto del recibo de los bultos siempre que se trate de daños aparentes y dentro de las 24 horas siguientes al recibo, si los daños fuesen no aparentes, la protesta o reserva debe hacerse por escrito.
- Las mercancías viajan siempre por cuenta y riesgo del comprador, aún en los casos de convenios especiales.
- Portes pagados:
 - a Península a partir de 250 €.
 - a Baleares a partir de 500 €.
 - a Canarias a partir de 1.500 €.
 - a Ceuta y Melilla, portes consultar.

RECLAMACIONES Y DEVOLUCIONES

No se aceptarán transcurridos QUINCE DÍAS de la fecha de recepción de la mercancía. Dará constancia a estos fines la fecha de albarán de entrega del transportista.

No se aceptará ninguna devolución de material sin su embalaje original y la conformidad expresa por parte de NOFER, S.L., ni se admitirán devoluciones en los artículos de fabricación especial.

Cualquier devolución injustificada de material, en caso de abonarse, sufrirá una depreciación automática mínima de 15% sobre el importe facturado en concepto de gastos de gestión y almacenaje, pudiendo ésta ser mayor después de peritación.

GARANTÍAS

Conforme a las condiciones descritas en los certificados incluidos en el apartado correspondiente, queda limitada simplemente a la sustitución de las piezas y recambios, reconocidos por el personal técnico de NOFER, S.L., en nuestra empresa, sin indemnización de clase alguna. La garantía no incluye el desplazamiento, ni la solución de aquellas averías producidas por causas ajenas al diseño o fabricación del producto o que estén originadas por un uso indebido, instalación o mantenimiento del mismo, ni por el desgaste común.

CONDICIONES DE PAGO

Hasta la concesión de la oportuna clasificación y riesgo, todas las operaciones serán abonadas mediante pago anticipado.

OPERACIONES SUCESIVAS

El aplazamiento de pago de nuestras facturas será el acordado entre ambas partes. Transcurridos los vencimientos acordados, quedamos automáticamente autorizados a contabilizar los intereses de demora a razón de un UNO POR CIENTO por mes o fracción.

IMPUESTOS

Cargados en factura conforme a la legislación vigente.

RESERVA DE DOMINIO

La mercancía se considera propiedad de NOFER, S.L. hasta el total pago de la misma por el cliente, teniendo NOFER, S.L. hasta ese momento reserva de dominio.

JURISDICCIÓN

Serán únicamente competentes, en caso de litigio, los Tribunales de Barcelona.

REPARACIONES

Se realizarán por los Servicios de Asistencia autorizados, o bien en NOFER, S.L., previa aceptación del correspondiente presupuesto. IMPORTANTE: coste del presupuesto 15 €.

● CONDIÇÕES DE VENDA

As descrições e fotografias contidas em nosso catálogo devem ser entendidas apenas em nível informativo. Nossa política é melhorar continuamente os produtos, por isso nos reservamos o direito de alterar as especificações sem aviso prévio.

PREÇOS

Os preços não incluem IVA ou outros impostos. Os preços de catálogo podem ser modificados sem aviso prévio e são válidos de acordo com a tarifa em vigor no dia da emissão.

PEDIDOS

Todas as encomendas devem ser formalizadas por documento escrito.

É imprescindível para fabricação de objetos especiais:

- Anexar esboços com as medidas do produto solicitado.
- Pagar 50% do valor no momento da aceitação do pedido. O restante será pago de acordo com as condições acordadas.
- Os preços não incluem a instalação nem seu envio.

PRAZOS DE ENTREGA

- A mercadoria incluída neste catálogo permanece sujeita a um processo de fabricação do produto solicitado pelo comprador, o prazo de entrega fornecido pela NOFER, S.L. terá o caráter orientativo ou aproximado no tempo.
- Os possíveis atrasos na entrega não poderão dar origem a qualquer penalização ou indenização por danos, nem permitirão ao comprador cancelar a encomenda.

TRANSPORTE DA MERCADORIA

- Quando a mercadoria é paga, a NOFER, S.L. está isenta de possíveis defeitos ou defeitos que possam ser atribuídos ao transporte das mercadorias.
- Quando a mercadoria viaja com frete pré-pago, o cliente deve notificar a NOFER, S.L. por escrito, no prazo de 24 horas após o recebimento da mercadoria, qualquer defeito ou problema atribuível à agência de transporte para facilitar a reivindicação de responsabilidade, em conformidade com a Lei 16/1987 sobre Transporte Terrestre e RD 1.111 / 1990 pelo qual é aprovado o regulamento LOTT.
- A reivindicação contra o transportador por danos ou mau funcionamento, deve ser realizado no ato de recepção dos pacotes fornecidos em caso de dano aparente e no prazo de 24 horas após a recepção, se os danos não eram aparentes, a manifestação ou reserva deve ser feito por escrito.
- As mercadorias viajam sempre por conta e risco do comprador, mesmo no caso de acordos especiais.
- Fretes Pagos:
 - a Península a partir de € 250.€
 - para as Ilhas Baleares a partir de 500 €.
 - às Ilhas Canárias a partir de 1.500 €.
 - para Ceuta e Melilla, por favor consulte.

RECLAMAÇÕES E DEVOLUÇÕES

Não serão aceitos após quinze dias da data de recebimento da mercadoria. A data de entrega da transportadora deve ser registrada para esses fins.

Não será aceita nenhuma devolução de material sem sua embalagem original e em conformidade ao expresso pela NOFER, S.L., nem serão aceitas devoluções de itens de fabricação especial. Qualquer devolução injustificada de material, se pago, sofrerá uma depreciação automática mínima de 15% sobre o valor faturado das despesas de gerenciamento e armazenagem, que podem ser maiores após a avaliação.

GARANTIAS

De acordo com as condições descritas nos certificados incluídos na seção correspondente, limita-se simplesmente à substituição de peças e peças sobresselentes, reconhecidas pelo pessoal técnico da NOFER, S.L., na nossa empresa, sem compensação de qualquer espécie. A garantia não inclui o deslocamento, nem a solução dessas avarias produzidas por motivos alheios ao projeto ou fabricação do produto ou que sejam causadas pelo uso, instalação ou manutenção inadequadas do mesmo, nem por desgaste normal.

CONDIÇÕES DE PAGAMENTO

Até a concessão da classificação e risco apropriados, todas as operações serão pagas mediante pagamento antecipado.

OPERAÇÕES SUCESSIVAS

O adiamento do pagamento de nossas faturas será acordado entre as duas partes. Uma vez que os vencimentos acordados tenham expirado, estamos automaticamente autorizados a contabilizar os juros de mora a uma taxa de UM PERCENT por mês ou fração.

IMPUESTOS

Cobrado na fatura de acordo com a legislação atual.

RESERVA DE PROPRIEDADE

A mercadoria é considerada propriedade da NOFER, S.L. até o pagamento total do mesmo pelo cliente, tendo a NOFER, S.L., até esse momento, reserva de propriedade.

JURISDIÇÃO

Em caso de litígio, os Tribunais de Barcelona serão os únicos competentes.

REPAROS

Eles serão executados pelos Serviços de Assistência autorizados, ou pela NOFER, S.L., após a aceitação do orçamento correspondente. IMPORTANTE: custo do orçamento 15 €.

● CONDIZIONI DI VENDITA

Le presenti condizioni di vendita e di consegna si intendono integralmente accettate dal Committente con il conferimento dell'ordine e con il ritiro dei materiali. Descrizioni e fotografie contenute nel nostro catalogo sono solo a titolo informativo. La politica aziendale è quella di migliorare continuamente i propri prodotti; quindi, ci riserviamo il diritto di cambiare le specifiche senza alcun preavviso.

ACCETTAZIONE DI ORDINI

- Gli ordini conferiti direttamente o per tramite di nostri rappresentanti od agenti, sono subordinati alla nostra accettazione.
- Tutti gli ordini devono essere formalizzati per iscritto.
- Su richiesta possiamo personalizzare i prodotti, Essenziale per una produzione personalizzata:
- Allegare un disegno tecnico con dimensioni del prodotto ordinato
- Pagare il 50% della somma totale al momento della conferma dell'ordine. Il restante sarà pagato in accordo con le condizioni pattuite. I prezzi non includono l'installazione e lo start-up.

CONDIZIONI DI CONSEGNA

Il termine di consegna ha valore semplicemente informativo e non impegnativo essendo subordinato ad eventuali imprevisti. I casi di forza maggiore quali contingentamenti, scioperi, mancanza di trasporti, ecc. ci dispensano dall'obbligo di mantenere i termini di consegna: il Committente non potrà esigere risarcimenti dovuti a danni di qualsiasi natura. Le spedizioni vengono effettuate con il mezzo ritenuto da noi più idoneo sempreché il Cliente non ci esprima la Sua preferenza. La merce viaggia a rischio e pericolo del Committente. Il destinatario è tenuto a controllare la merce in arrivo e contestare eventuali danni direttamente al vettore anche quando la merce è recapitata in porto franco. Imprescindibile para la fabricación especial.

CONDIZIONI DI RESA

Per ordini superiori ai 500 Euro la merce è resa in porto franco in tutta Italia, isole escluse. Per Sicilia e Sardegna la merce è resa in porto franco per ordini superiori ai 2000 Euro. Per ordini inferiori a tali importi la merce è resa franco nostro magazzino e comunque in conformità con le condizioni riportate sulla conferma d'ordine

PREZZI

I prezzi si intendono in Euro; i prezzi possono essere variati senza alcun preavviso e si intendono riferiti ai listini in vigore al momento della consegna.

RECLAMI E RIMBORSI

Non saranno accettati dopo 15 giorni dalla data di ricezione della merce. La data che appare sulla notifica del corriere non corrisponde alla data di ricezione della merce. Nessun rimborso sarà accettato senza l'imballo originale della BOCCHI SAFEWORK NOFER e senza il consenso da parte dell'azienda. Non sono effettuabili rimborsi per produzioni personalizzate.

Ogni ingiustificata restituzione di merce, se già pagata, sarà deprezzata del 15% sul valore riportato in fattura, per spese di gestione. Il deprezzamento può essere aumentato a seguito di una nostra attenta valutazione

PAGAMENTI

I pagamenti devono essere effettuati direttamente alla Società presso la sua sede. Hanno effetto liberatorio solo i pagamenti in contanti. Ogni altra forma di pagamento (assegni di c / c, circolari, vaglia, cambiali, tratte, ecc.) resta a completo rischio e spesa del Committente e si intende accettata salvo buon fine. Le condizioni stabilite, e la data di pagamento in fattura assumono carattere di condizione essenziale; qualsiasi ritardo imputabile al Committente o qualsiasi contestazione sorgesse fra le parti anche relativamente alle garanzie concesse non produrrà alcun prolungamento o modifica nei termini dei pagamenti convenuti e ogni azione ed eccezione del compratore non sarà ritenuta procedibile, se lo stesso non proverà di essere in regola con i pagamenti. Sui pagamenti non effettuati alla scadenza, decorreranno gli interessi di mora nella misura stabilita dal D. Lgs 231 / 2002-Art.5- (tasso BCE maggiorato di 7 punti percentuali) ed inoltre la Bocchi avrà diritto di sospendere ogni altra consegna senza necessità di preavvisi ritenendo annullato per colpa della ditta acquirente l'ordine in corso per la parte non ancora consegnata; è fatto salvo il risarcimento dei danni.

IMBALLAGGIO

L'imballaggio viene effettuato con imballi specifici. L'imballaggio standard è compreso nel costo del prodotto. Imballaggi speciali, pallets, gabbie, ecc., saranno addebitati al Committente al costo.

GARANZIA

Tutti i materiali vengono scrupolosamente provati e collaudati; la Bocchi Safework Nofer srl non garantisce l'impiego errato o inadatto della merce fornita e pertanto nessuna responsabilità potrà esserle attribuita a qualsiasi titolo e nessun in-dennizzo potrà essere richiesto. Qualora il materiale risultasse accidentalmente difettoso per vizi di fabbricazione ricolpiti a seguito di accertamenti tecnici, la Bocchi Safework Nofer srl si riserva di sostituirlo o di accreditarne il valore qualora ritenga più conveniente procedere alla sua distruzione in loco. Viene declinata ogni responsabilità per danni accertati ad altro titolo. La merce in contestazione ci deve essere resa in porto franco. Il periodo di garanzia, salvo diversa indicazione scritta, è di 12 mesi dalla data di installazione, con un massimo di 18 mesi (6 mesi extra) rispetto alla data di vendita.

FORO COMPETENTE

Qualsiasi controversia fra la Bocchi Safework Nofer srl e il Committente sarà di competenza soltanto dell'autorità di Milano, esclusa qualsiasi deroga, anche nel caso di chiamate in giudizio per garanzia, connessione, contigenza di lite.

◎ CONDITIONS DE VENTE

Les descriptions et les photos contenues dans notre catalogue sont uniquement à titre informatif. Notre politique est basée sur l'amélioration continue des produits, c'est la raison pour laquelle nous nous réservons le droit de modifier les caractéristiques sans préavis.

PRIX

Les prix ne comprennent ni TVA ni d'autres taxes. Les prix indiqués sur le catalogue peuvent être modifiés sans préavis et sont valables selon les tarifs en vigueur du jour de l'expédition.

COMMANDES

Toutes les commandes doivent être présentées par écrit. Indispensable pour la fabrication spéciale.

- Joindre le croquis avec les dimensions du produit demandé
- Payer 50% du montant au moment de l'acceptation de la commande. Le reste sera payé selon les conditions convenues.
- Les prix ne comprennent pas l'installation ni sa mise en oeuvre.

DÉLAIS DE LIVRAISON

- Les produits du présent catalogue sont sujets à un processus de fabrication selon la demande de l'acheteur.
- Le délai de livraison facilité par NOFER, S.L. doit être considéré comme indicatif ou approximatif.
- Les éventuels retards de livraison ne seront en aucun cas pénalisés ou indemnisés pour dommages et intérêts, ni habiliteront l'acheteur à annuler la commande.

TRANSPORT DE LA MARCHANDISE

- Lorsque l'expédition de marchandise est en port dû (non payé), Nofer, S.L. ne se considère pas responsable d'éventuels défauts qui pourraient être attribués au transport de la marchandise.
- Lorsque l'expédition de marchandise est en port payé, le client a l'obligation d'informer NOFER, S.L. par écrit, de n'importe quel dommage ou imperfection qui pourraient être attribués à l'agence de transport pour faciliter la réclamation de responsabilité conformément à la loi 16/1987 de la gestion des transports terrestres et RD 1111 / 1990 qui approuve le règlement LOTT.
- La réclamation pour défaillance ou dommage, contre les transporteurs, doit se faire au moment de la réception des colis, dans le cas où les dommages sont apparents, et dans les 24 heures qui suivent la réception, si les dommages ne sont pas apparents. La réclamation doit se faire par écrit.
- L'expédition de la marchandise est toujours aux risques de l'acheteur, même dans les cas de conventions particulières.
- Port payé :
 - À la Péninsule à partir de 250 €.
 - Aux Baléares à partir de 500 €.
 - Aux Canaries à partir de 1500 €.
 - À Ceuta et Melilla nous consulter.

RÉCLAMATIONS ET REMBOURSEMENTS

Ne seront pas acceptés après un délai de QUINZE JOURS suite à la réception de la marchandise.

Le délai sera confirmé par la date affichée sur le bordereau de livraison du transporteur. Aucun retour ne sera accepté sans son emballage d'origine et la conformité de la part de NOFER, S.L., ni sera accepté le retour des articles spécialement conçus pour le client. Tout retour injustifié des produits, subira une dépréciation automatique minimale de 15% sur le montant facturé pour les frais de gestion et de stock, pouvant être plus élevé après une expertise.

GARANTIES

Conforme aux conditions décrites dans les certificats inclus dans la section correspondante, la substitution des pièces et les rechanges, se feront uniquement par l'approbation du personnel technique de NOFER, S.L., dans notre société, et sans aucun type d'indemnisation. La garantie ne couvre ni déplacement ni la solution aux pannes produites par des causes qui n'ont rien à voir avec la conception ou la fabrication du produit, ou causée par une mauvaise utilisation, installation ou entretien de celui-ci, ou par l'usure commune.

CONDITIONS DE PAIEMENT

Jusqu'à l'octroi des classifications et des risques, toutes les opérations seront réglées par prépaiement.

OPERATIONS SUCCESSIVES

L'ajournement de paiement de nos factures sera le convenu entre les deux parties. Après les échéances convenues, nous seront automatiquement autorisés à tenir compte des intérêts de retard à raison de 1 % par mois ou fraction de celui-ci.

TAXES

Appliqués sur la facture conformément à la législation en vigueur.

RÉSERVE DE PROPRIÉTÉ

La marchandise est considérée comme propriété de Nofer, S.L. jusqu'à la totalité de son paiement par le client, ce qui autorise NOFER, S.L. à la réserve de propriété jusqu'à ce moment-là.

COMPÉTENCE JUDICIAIRE

En cas de conflit, les tribunaux de Barcelone seront la compétence exclusive.

REPARATIONS

Seront réalisées par les services d'assistance autorisés ou par Nofer, S.L., suite à l'acceptation du devis correspondant.

IMPORTANT: le devis coûte 15 €.

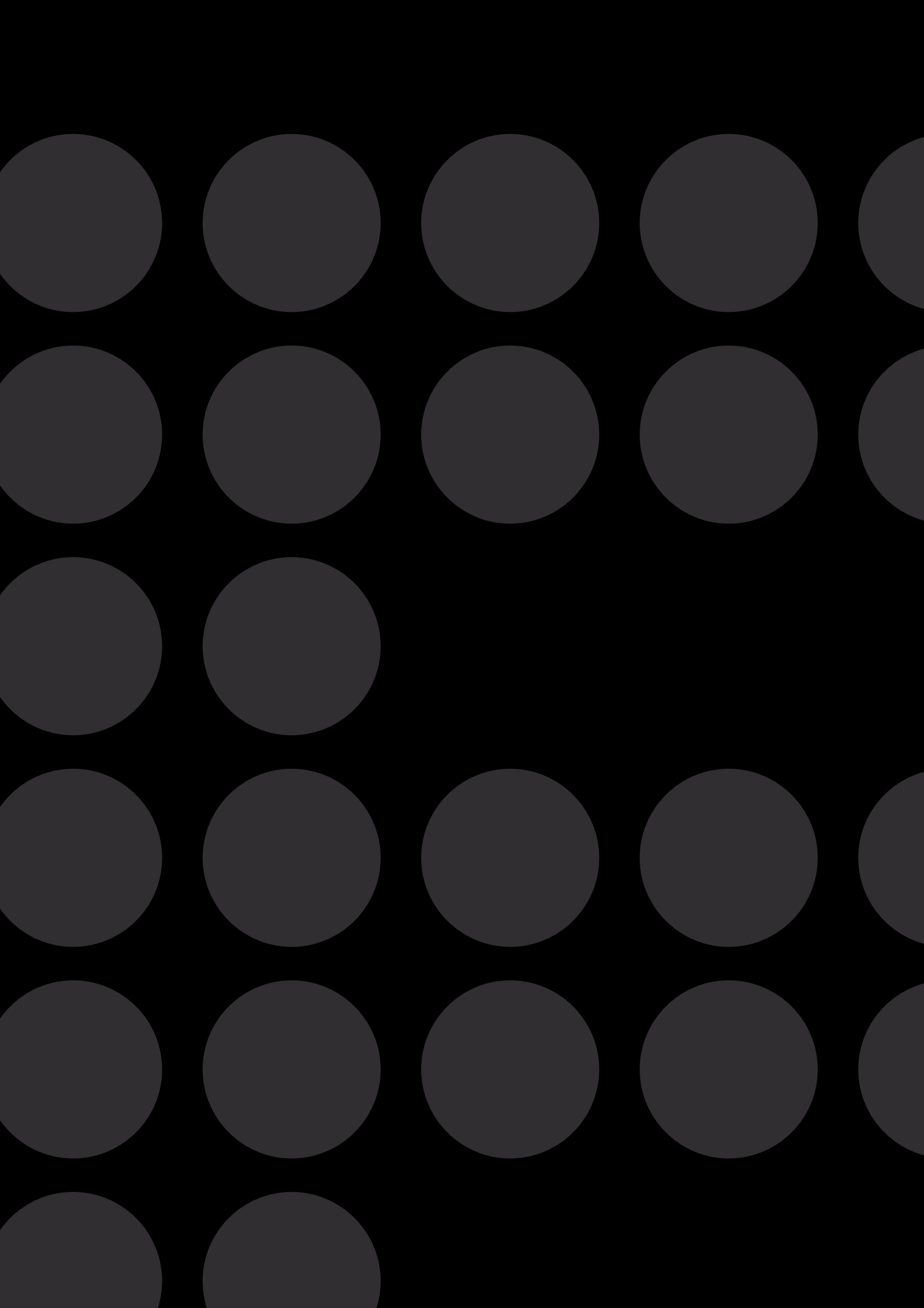

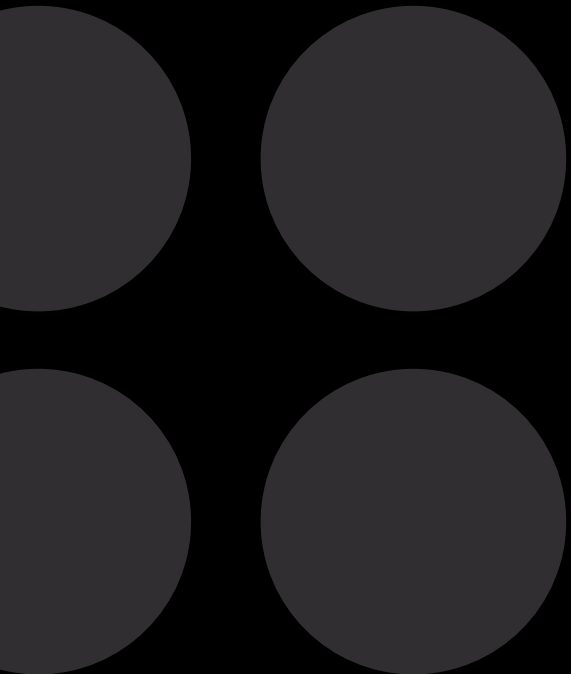

NOIFER®

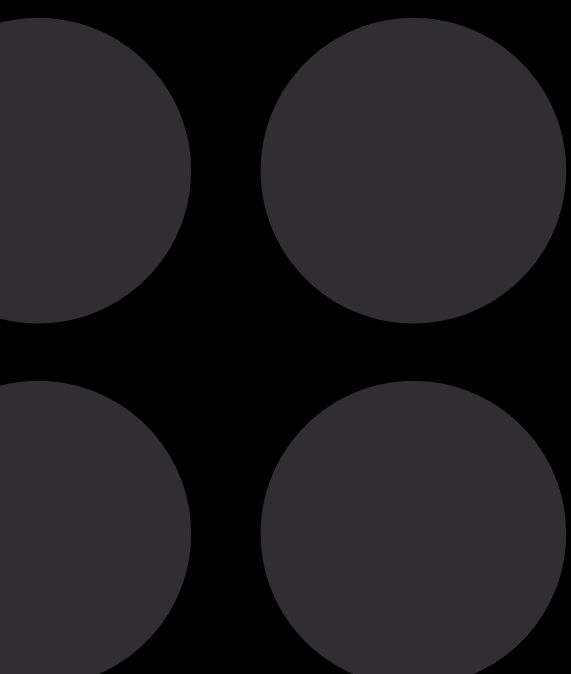

NOFER S.L.

Ctra. Laureà Miró, 385-387
08980 Sant Feliu de Llobregat
Barcelona – Spain

☎ +34 934 742 423

☎ +34 934 743 548

✉ nofer@nofer.com

🌐 www.nofer.com

MILANO  GIAMPIERI
rubinetteria milano

BOCCHISAFEWORK, S.R.L

Via torino, 10 – 20060 Liscate
Milano – Italy

☎ +39 0249 796141

✉ info-bocchi@nofer.com

MOSCOW

107133, Moscow – Shumkina str.26a str.4
Russian Federation

☎ -7 (495) 602-05-85

✉ info@nofer-aporici.ru

DUBAI

Office #1, Industrial Area, Maliha Road,
P.O. Box, 4316, Sharjah, UAE

☎ +971 65467420

✉ info@mena-gate.com



NOFER
BRAND GROUP

NOFER



DECOSAN

BOCCHI SafeWORK

agelar, s.a.